



ROTAMATIC PU1DR

UNDERSPEED MOTION MONITOR



CE
UK
CA



INSTALLATION INSTRUCTIONS



OPERATION MANUAL

PU1DR

www.go4b.com

TABLE OF CONTENTS

| | |
|----------------------------------|------------|
| CUSTOMER SAFETY RESPONSIBILITIES | Page 3 - 4 |
| PRODUCT OVERVIEW | Page 5 |
| SPECIFICATIONS | Page 5 |
| DIMENSIONS | Page 6 |
| INSTALLATION | Page 6 |
| STANDARD WIRING DIAGRAM | Page 7 |
| SENSOR CALIBRATION | Page 8 |
| TESTING & COMMISSIONING | Page 9 |
| TROUBLESHOOTING GUIDE | Page 9 |
| PRODUCT WARRANTY | Page 10 |

| | |
|--|--|
|   | <p> WARNING</p> <p>Rotating parts can crush, cut and entangle.</p> <p>Do NOT operate with guard removed.</p> <p>Lockout power before removing guard or servicing.</p> |
|--|--|

Dear 4B Customer:

Congratulations on your purchase. 4B appreciates your business and is pleased you have chosen our products to meet your needs.

Please read in its entirety and understand the literature accompanying the product before you place the product into service. Please read the safety precautions carefully before operating the product. With each product you purchase from 4B, there are some basic but important safety considerations you must follow to be sure your purchase is permitted to perform its design function and operate properly and safely, giving you many years of reliable service. Please read and understand the Customer Safety Responsibilities listed below. Failure to follow this safety directive and the Operation Manuals and other material furnished or referenced, may result in serious injury or death.

SAFETY NOTICE TO OUR CUSTOMERS

- A. In order to maximize efficiency and safety, selecting the right equipment for each operation is vital. The proper installation of the equipment, and regular maintenance and inspection is equally important in continuing the proper operation and safety of the product. The proper installation and maintenance of all our products is the responsibility of the user unless you have asked 4B to perform these tasks.
- B. All installation and wiring must be in accordance with Local and National Electrical Codes and other standards applicable to your industry. The installation of the wiring should be undertaken by an experienced and qualified professional electrician. Failure to correctly wire any product and/or machinery can result in the product or machine failing to operate as intended, and can defeat its design function.
- C. Periodic inspection by a qualified person will help assure your 4B product is performing properly. 4B recommends a documented inspection at least annually and more frequently under high use conditions.
- D. Please see the last page of this manual for all warranty information regarding this product.

CUSTOMER SAFETY RESPONSIBILITIES

1. READ ALL LITERATURE PROVIDED WITH YOUR PRODUCT

Please read all user, instruction and safety manuals to ensure that you understand your product operation and are able to safely and effectively use this product.

2. YOU BEST UNDERSTAND YOUR NEEDS

Every customer and operation is unique, and only you best know the specific needs and capabilities of your operation. Please go to www.go4b.com or call the 24-hour hotline at +1-309-698-5611 for assistance with any questions about the performance of products purchased from 4B. 4B is happy to discuss product performance with you at any time.

3. SELECT A QUALIFIED AND COMPETENT INSTALLER

Correct installation of the product is important for safety and performance. If you have not asked 4B to perform the installation of the unit on your behalf, it is critical for the safety of your operation and those who may perform work on your operation that you select a qualified and competent electrical installer to undertake the installation. The product must be installed properly to perform its designed functions. The installer should be qualified, trained, and competent to perform the installation in accordance with local and national electrical codes, all relevant regulations, as well as any of your own standards and preventive maintenance requirements, and other product installation information supplied with the product. You should be prepared to provide the installer with all necessary installation information to assist in the installation.

4. ESTABLISH AND FOLLOW A REGULAR MAINTENANCE AND INSPECTION SCHEDULE FOR YOUR 4B PRODUCTS

You should develop a proper maintenance and inspection program to confirm that your system is in good working order at all times. You will be in the best position to determine the appropriate frequency for inspection. Many different factors known to the user will assist you in deciding the frequency of inspection. These factors may include but are not limited to weather conditions; construction work at the facility; hours of operation; animal or insect infestation; and the real-world experience of knowing how your employees perform their jobs. The personnel or person you select to install, operate, maintain, inspect or perform any work whatsoever, should be trained and qualified to perform these important functions. Complete and accurate records of the maintenance and inspection process should be created and retained by you at all times.

5. RETAIN AND REFER TO THE OPERATION MANUAL FOR 4B'S SUGGESTED MAINTENANCE AND INSPECTION RECOMMENDATIONS

As all operations are different, please understand that your specific operation may require additional adjustments in the maintenance and inspection process essential to permit the monitoring device to perform its intended function. Retain the Operation Manual and other important maintenance and service documents provided by 4B and have them readily available for people servicing your 4B equipment. Should you have any questions, please call go to www.go4b.com or call the 24-hour hotline at +1-309-698-5611.

6. SERVICE REQUEST

If you have questions or comments about the operation of your unit or require the unit to be serviced please contact the 4B location who supplied the product or call us via our 24-hour hotline number in the USA (309-698-5611). Please have available product part numbers, serial numbers, and approximate date of installation. In order to assist you, after the product has been placed into service, complete the online product registration section which is accessed via our website www.go4b.com.

WARNING

- Rotating machinery can cause serious injury or death
- Always lockout and tagout the machine prior to installation

PRODUCT OVERVIEW

The Rotamatic PU1DR is a self contained self calibrating, micro-computer based, under-speed monitor. It consists of an inductive proximity sensor and associated underspeed monitoring circuitry, all housed in a DIN standard limit switch size package.

Calibration is achieved by applying a magnet to a calibration point, whilst running the machinery to be monitored at the correct speed. No contact is made between the sensor and plant being monitored. The proximity sensor detects a stud or bolt mounted on the shaft or machinery.

The unit works on 12-240V dc or 24 to 240V ac. The PU1DR incorporates a programmable start up delay of up to 60 seconds, to allow moving parts to achieve correct speed, thereafter, if the pulse rate falls 20% below set rate, a fault signal is indicated. The unit is ideal for monitoring grain elevators, belt driven fans, conveyors etc. but may be used to monitor any rotating or reciprocating machinery.

SPECIFICATIONS

| | |
|------------------------|---|
| Supply Voltage: | 12-240VDC or 24-240VAC (50-60Hz) |
| Supply Rating: | 2VA |
| Switching Capacity: | 3A 240V non-inductive maximum |
| Operating Distance: | 12mm Maximum (Ferrous) |
| Target | Ferrous or Non-Ferrous Stud or Bolt |
| Output: | S.P.C.O. Relay |
| Indication: | Target Detected & Output Energised/ Fault Condition LED's. (See chart). |
| Operating Speed: | 10 - 4000 p.p.m. |
| Repeat accuracy: | Better than 1%. |
| Operating Temperature: | -15°C to +50°C. |
| Enclosure Material | PET/PEN Co-polymer |
| Start-up Delay | Programmable 0 - 60 Seconds |
| Operation Setting: | Automatic calibration by applying magnet to 'Cal' point. Relay deenergises at 20% under set speed |
| Conduit Fitting: | M20 x 1.5 tapped female thread |
| IP Rating: | IP65 |
| Weight: | 350gms |
| Cable: | Supplied with 2 metres 5 core PVC. |

DIMENSIONS

Dimensions

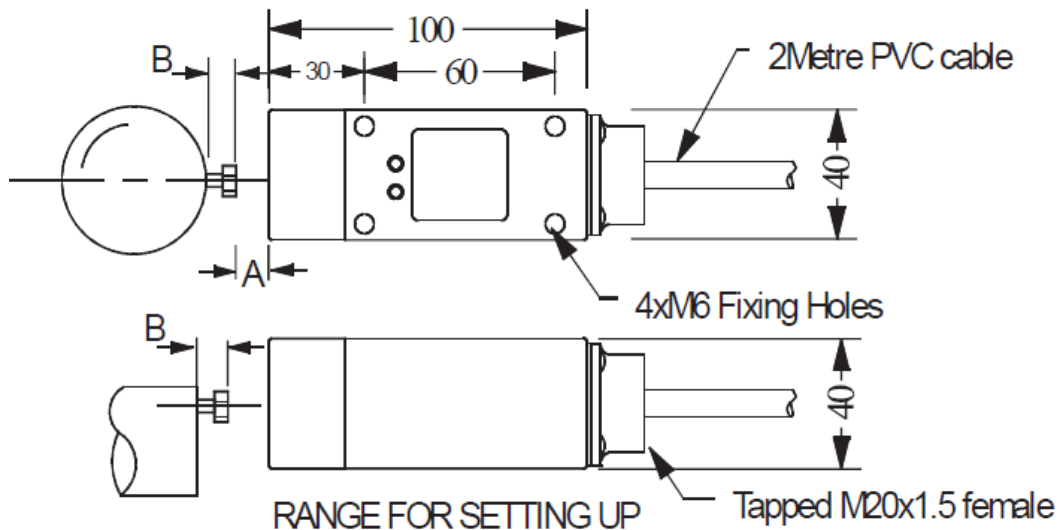

A = 15mm max for ferrous target

A = 9mm for non ferrous target



B = 12mm minimum

INSTALLATION

The PU1DR should be wired as shown in the connection diagram. Cable can be virtually any length required, using ordinary unscreened cable. However, if long cable runs are to be used, the M750 wiring should not be positioned with cables carrying high voltage or current. Ensure that the unit is mounted securely to withstand vibration and that target distances shown are maintained.

Note! When installing the PU1DR unit in an exterior location, a suitable UV shield should be fitted over the unit. If located in an area with a high risk of impact additional guarding/protection MUST be fitted. Do not mount the snout of the PU1DR flush onto surrounding metal, since this will cause the sensor to 'latch' on permanently. The sensor snout should overhang metal by at least 10mm and have as much air gap around it as possible.

The product is IP65 rated and can be installed in indoor and outdoor environments. Installation is to be at an altitude of $\leq 2000\text{m}$ (~6500ft) and at least relative humidity of 80% (31°C). Unit input voltage can operate with at least 10% input fluctuations, and the Product is Overvoltage Category II. The product makes no audible sound.

| | |
|---|--|
|  | ⚠ WARNING |
|  | Rotating parts can crush, cut and entangle. |
| | Do NOT operate with guard removed. |
| | Lockout power before removing guard or servicing. |

⚠ WARNING

O.S.H.A. requires that all exposed rotating shafts are provided with a full guard. Therefore, this device and its target must be equipped with a guard.

Fasten the PU1DR to a suitable mounting bracket, such as 4B's Whirligig® universal shaft sensor mount, with the nose of the switch within the sensing range of the target, as shown below -



STANDARD WIRING DIAGRAM

Connections

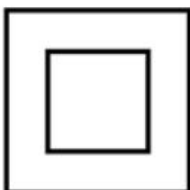
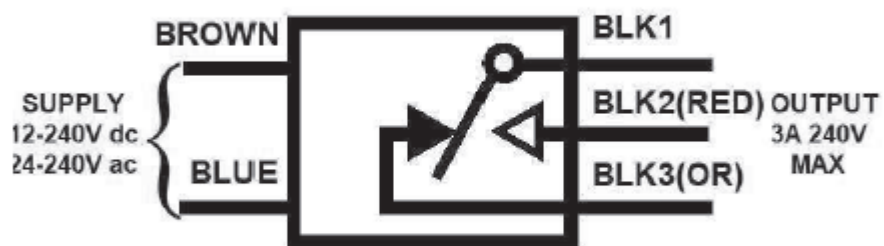

Note: Double insulation, does not require a safety connection to electrical earth (ground).

WARNING

Do NOT recalibrate sensor due to belt slipping issues.

Commissioning & Auto-calibration

Two LED's are provided for information purposes, on the PU1DR. The input LED is red and flashes everytime a target passes the face of the sensor. The output LED is tri-colour. Under normal running, the output LED is a static green. Under fault conditions, the colour may be orange or red (see table for fault codes). The PU1DR is factory set to a speed of 10PPM and a start up time of 5 seconds.

If the time delay required is greater than 5 seconds, see 'Recalibration for a different setting', otherwise, proceed as follows -

Apply power to the machine and PU1DR. Ensure that the machine has reached normal running speed and then place the magnet on the 'Cal' point, Count flashes of the green LED to set the start delay required in seconds, then remove magnet. The LED will echo the setting in seconds, during which time, automatic calibration to 20% below normal speed will be carried out.

Recalibration for a Different Setting:

If the unit is to be used for a slower speed or with longer time delay than previously set, the unit may trip out before it can be calibrated. This can be avoided by applying power while holding the magnet on the Cal point and removing the magnet only when the machine has reached normal speed. Wait for the green LED to illuminate permanently and then recalibrate as above.

OUTPUT LED FAULT CODE:

Orange: Programming not accepted, unit has defaulted back to previous programme settings and requires re-programming.

Red: Follow procedure "Recalibration for a different setting". If the output LED remains red, contact your supplier.

TESTING AND COMMISSIONING

1. Check that the unit is correctly installed (see standard wiring diagram).
2. Check that the distance between the target, stud or bolt head and sensing face of the PU1DR is within the minimum distance specified.
3. Start up machine, and wait for start-up delay to complete (set LED will be solid green).
4. 4B's *SpeedMaster™* calibration and testing device can be used to accurately test the shutdown features of the PU1DR. A metal putty knife or a small piece of metal can be used to simulate a stop motion situation by placing the metal between the sensing face of the PU1DR and the target. After the initial start up delay, the machine should shutdown.

SPEEDMASTER™



Patents -
US8947073
MX321802
EP26223568

The *SpeedMaster™* with Pulse Pilot is the only device that accurately tests the calibration of a speed switch, and allows testing of the alarm and shutdown features of the sensor while installed on the machine shaft.

The *SpeedMaster™* operates in two modes. Input mode is used to measure the pulse rate at normal speed. Output mode will allow the user to input pulses to the sensor for testing purposes.

The Pulse Pilot fits between the gap between the sensor and the target. The Pulse Pilot will have no effect on the operation of the speed switch until it is connected to the *SpeedMaster™* and set to “output” mode.

⚠ WARNING

If the system does not immediately shutdown as expected or alarm as required, then remove the machine from service until the problem has been diagnosed and corrected.

TROUBLESHOOTING GUIDE

| FAULT | REMEDY |
|---|---|
| Set LED is OFF; Input LED is pulsing | Currently measured speed is more than 20% (below the calibrated speed). Check machine speed is correct and belt is not slipping. If needed, recalibrate sensor (see page 8). |
| Input LED does not illuminate | Check that you have a supply of the correct value across the blue and brown wires. Slide a screwdriver blade across the face of the sensor, the input LED should flicker. If not, contact 4B. If the input LED does flicker, move the front face of the sensor closer to the target and check the target size as specified under “INSTALLATION”. |
| Input LED Stays on Permanently | Either increase the gap between the target and the shaft, or between the target and the sensor face. |

PRODUCT WARRANTY

1. EXCLUSIVE WRITTEN LIMITED WARRANTY

All products sold are warranted by the company 4B Components Limited, 4B Braime Components Limited, and 4B France herein after referred to as 4B to the original purchaser against defects in workmanship or materials under normal use for one (1) year after date of purchase from 4B. Any product determined by 4B at its sole discretion to be defective in material or workmanship and returned to a 4B branch or authorized service location, as 4B designates, shipping costs prepaid, will be, as the exclusive remedy, repaired or replaced at 4B's option.

2. DISCLAIMER OF IMPLIED WARRANTY

No warranty or affirmation of fact, expressed or implied, other than as set forth in the exclusive written limited warranty statement above is made or authorized by 4B. 4B specifically disclaims any liability for product defect claims that are due to product misuse, abuse or misapplications, as authorized by law, 4B specifically disclaims all warranties that the product is fit or merchantable for a particular purpose.

3. NO WARRANTY "BY SAMPLE OR EXAMPLE"

Although 4B has used reasonable efforts to accurately illustrate and describe the products in its catalogs, literature, and websites, such illustrations and descriptions are for the sole purpose of product identification and do not express or imply a warranty affirmation of fact, of any kind or a warranty or affirmation of fact that the products will conform to their respective illustrations or descriptions. 4B expressly disclaims any warranty or affirmation of fact, expressed or implied, other than as set forth in the exclusive written limited warranty statement above, including, without limitation, the implied warranties of merchantability and fitness for a particular purpose.

4. LIMITATION OF DAMAGES

Any liability for consequential, incidental, special, exemplary, or punitive damages, or for loss of profit whether direct or indirect, is expressly disclaimed.

With subsidiaries in North America, Europe, China, Asia, Africa and Australia along with a worldwide network of distributors, 4B can provide practical solutions for all your applications no matter the location.



4B BRAIME COMPONENTS LTD.

Hunslet Road
Leeds
LS10 1JZ
United Kingdom
Tel: +44 (0) 113 246 1800
Email: 4b-uk@go4b.com

4B DEUTSCHLAND

35 Bis Rue Du 8 Mai 1945
80800 Villers, Bretonneux
France
Tel: +49 (0) 700 2242 4091
Email: 4b-deutschland@go4b.com

4B AFRICA

14 Newport Business Park
Mica Drive, Kya Sand
2163 Johannesburg
South Africa
Tel: +27 (0) 11 708 6114
Email: 4b-africa@go4b.com

4B FRANCE

35 Bis Rue Du 8 Mai 1945
80800 Villers, Bretonneux
France
Tel: +33 (0) 3 22 42 32 26
Email: 4b-france@go4b.com

4B COMPONENTS LTD.

625 Erie Avenue
Morton, IL 61550
USA
Tel: 309-698-5611
Fax: 309-698-5615

4B ASIA PACIFIC

Build No. 899/1 Moo 20
Soi Chongsiri, Bangplee-Tam
Ru Road, Tanbon Bangpleeyai,
Amphur Bangplee,
Samutprakarn 10540
Thailand
Tel: +66 (0) 2 173-4339
Email: 4b-asiapacific@go4b.com

4B China

F1, Building 5A,
Jintong Industrial Park,
8 West Lake Road,
Wujin High & New TDZ,
Changzhou, Jiangsu, PRC
Tel: +86-519-88556006
Email: 4b-china@go4b.com

4B AUSTRALIA

Building 1, 41 Bellrick Street
Acacia Ridge
Queensland 4110
Australia
Tel: +61 (0)7 3216 9365
Email: 4b-australia@go4b.com



www.go4b.com