



Digimatic™

RADIO FREQUENCY (RF) CAPACITANCE
POINT LEVEL INDICATOR



INSTALLATION INSTRUCTIONS

OPERATION MANUAL

Part No DML4W

www.go4b.com

TABLE OF CONTENTS

CUSTOMER SAFETY RESPONSIBILITIES	Page 4 - 5
PRODUCT OVERVIEW	Page 6
SPECIFICATIONS	Page 6
DIMENSIONS	Page 7
INSTALLATION	Page 8
STANDARD WIRING DIAGRAM	Page 9
SENSOR OPERATION	Page 10 - 11
SENSOR CALIBRATION	Page 12 - 13
POWER SHIELD OVERVIEW	Page 14
TESTING AND COMMISSIONING	Page 15
TROUBLESHOOTING GUIDE	Page 15
PARTS AND ACCESSORIES	Page 16
PRODUCT WARRANTY	Page 17

Dear 4B Customer:

Congratulations on your purchase. 4B appreciates your business and is pleased you have chosen our products to meet your needs.

Please read in its entirety and understand the literature accompanying the product before you place the product into service. Please read the safety precautions carefully before operating the product. With each product you purchase from 4B, there are some basic but important safety considerations you must follow to be sure your purchase is permitted to perform its design function and operate properly and safely, giving you many years of reliable service. Please read and understand the Customer Safety Responsibilities listed below. Failure to follow this safety directive and the Operation Manuals and other material furnished or referenced, may result in serious injury or death.

SAFETY NOTICE TO OUR CUSTOMERS

- A. In order to maximize efficiency and safety, selecting the right equipment for each operation is vital. The proper installation of the equipment, and regular maintenance and inspection is equally important in continuing the proper operation and safety of the product. The proper installation and maintenance of all our products is the responsibility of the user unless you have asked 4B to perform these tasks.
- B. All installation and wiring must be in accordance with Local and National Electrical Codes and other standards applicable to your industry. The installation of the wiring should be undertaken by an experienced and qualified professional electrician. Failure to correctly wire any product and/or machinery can result in the product or machine failing to operate as intended, and can defeat its design function.
- C. Periodic inspection by a qualified person will help assure your 4B product is performing properly. 4B recommends a documented inspection at least annually and more frequently under high use conditions.
- D. Please see the last page of this manual for all warranty information regarding this product.

CUSTOMER SAFETY RESPONSIBILITIES

1. READ ALL LITERATURE PROVIDED WITH YOUR PRODUCT

Please read all user, instruction and safety manuals to ensure that you understand your product operation and are able to safely and effectively use this product.

2. YOU BEST UNDERSTAND YOUR NEEDS

Every customer and operation is unique, and only you best know the specific needs and capabilities of your operation. Please go to www.go4b.com or call the 24-hour hotline at +1-309-698-5611 for assistance with any questions about the performance of products purchased from 4B. 4B is happy to discuss product performance with you at any time.

3. SELECT A QUALIFIED AND COMPETENT INSTALLER

Correct installation of the product is important for safety and performance. If you have not asked 4B to perform the installation of the unit on your behalf, it is critical for the safety of your operation and those who may perform work on your operation that you select a qualified and competent electrical installer to undertake the installation. The product must be installed properly to perform its designed functions. The installer should be qualified, trained, and competent to perform the installation in accordance with local and national electrical codes, all relevant regulations, as well as any of your own standards and preventive maintenance requirements, and other product installation information supplied with the product. You should be prepared to provide the installer with all necessary installation information to assist in the installation.

4. ESTABLISH AND FOLLOW A REGULAR MAINTENANCE AND INSPECTION SCHEDULE FOR YOUR 4B PRODUCTS

You should develop a proper maintenance and inspection program to confirm that your system is in good working order at all times. You will be in the best position to determine the appropriate frequency for inspection. Many different factors known to the user will assist you in deciding the frequency of inspection. These factors may include but are not limited to weather conditions; construction work at the facility; hours of operation; animal or insect infestation; and the real-world experience of knowing how your employees perform their jobs. The personnel or person you select to install, operate, maintain, inspect or perform any work whatsoever, should be trained and qualified to perform these important functions. Complete and accurate records of the maintenance and inspection process should be created and retained by you at all times.

5. RETAIN AND REFER TO THE OPERATION MANUAL FOR 4B'S SUGGESTED MAINTENANCE AND INSPECTION RECOMMENDATIONS

As all operations are different, please understand that your specific operation may require additional adjustments in the maintenance and inspection process essential to permit the monitoring device to perform its intended function. Retain the Operation Manual and other important maintenance and service documents provided by 4B and have them readily available for people servicing your 4B equipment. Should you have any questions, please call go to www.go4b.com or call the 24-hour hotline at +1-309-698-5611.

6. SERVICE REQUEST

If you have questions or comments about the operation of your unit or require the unit to be serviced please contact the 4B location who supplied the product or call us via our 24-hour hotline number in the USA (309-698-5611). Please have available product part numbers, serial numbers, and approximate date of installation. In order to assist you, after the product has been placed into service, complete the online product registration section which is accessed via our website www.go4b.com.

PRODUCT OVERVIEW

The DIGIMATIC is a fixed point Level Controller incorporating a microcomputer which is used to automatically calibrate the probe to suit the material being detected. Full manual override facilities are included. The DIGIMATIC employs a power shield to minimise the effect of material adhering to the probe making it ideal for detecting most materials including sticky or viscous types. It is equally suited to both liquids and solids. The probe may be a solid rod, metal plate or wire rope. The self contained DIGIMATIC is normally supplied with a loose probe, available as a stainless steel rod in standard lengths of 100mm, 1 metre or 2 metres, or as a 10 metre wire rope suspension probe and weight. The probe should be screwed to the DIGIMATIC. Prior to attachment, the probe length can be reduced or increased, if desired, but see notes a) and b) regarding minimum surface area.

NOTES:-
The DIGIMATIC sensitivity is proportional to the surface area of the probe. When using a 16mm dia. probe the minimum length to use, for the majority of materials, is 200mm. This should be treated as the minimum if possible.
If the probe length needs to be reduced to less than 200mm, the surface area should be maintained. This can be achieved by increasing the diameter, by fitting a metal tube over the probe, or by bending the probe rod. In certain high density materials it may be possible to reduce the length without compensation.

SPECIFICATIONS

Power Supply -	110V/230V ac 50/60 Hz or 24V dc (Stabilised) (+6.5% to -10%).
Operating Temp. -	-20° C to 50° C
Output -	S.P.C.O 240 VAC Contacts Rated at 2.5 Amps non-inductive
Mounting -	Via 1" BSP Parallel thread
Fail Safe -	Low Level or High Level (Selectable)
Calibration -	Push Button (With or Without Material)
LED Display -	Measured Values (Covered, Uncovered, Trip)
LED Indicator -	Material Detection
Time Delay -	0 - 128 second variable. (prevents false signaling from splashing).
Probes -	Stainless Steel, available in 100mm, 1 metre, 2 metre, or 10 metre wire rope
Conduit Entry -	Two conduit entry tapped 20mm (One blind, drill out to use).
Enclosure -	Modified Polyamide 66.
Protection -	IP65
Earth Bonding -	Earth stud located on exterior of main case. This stud must be connected to earth, bonded to container or metalwork of container and exterior of armour cabling, if used

DIMENSIONS

L = 60mm for DML4(S)

L = 121mm for DML4W standard

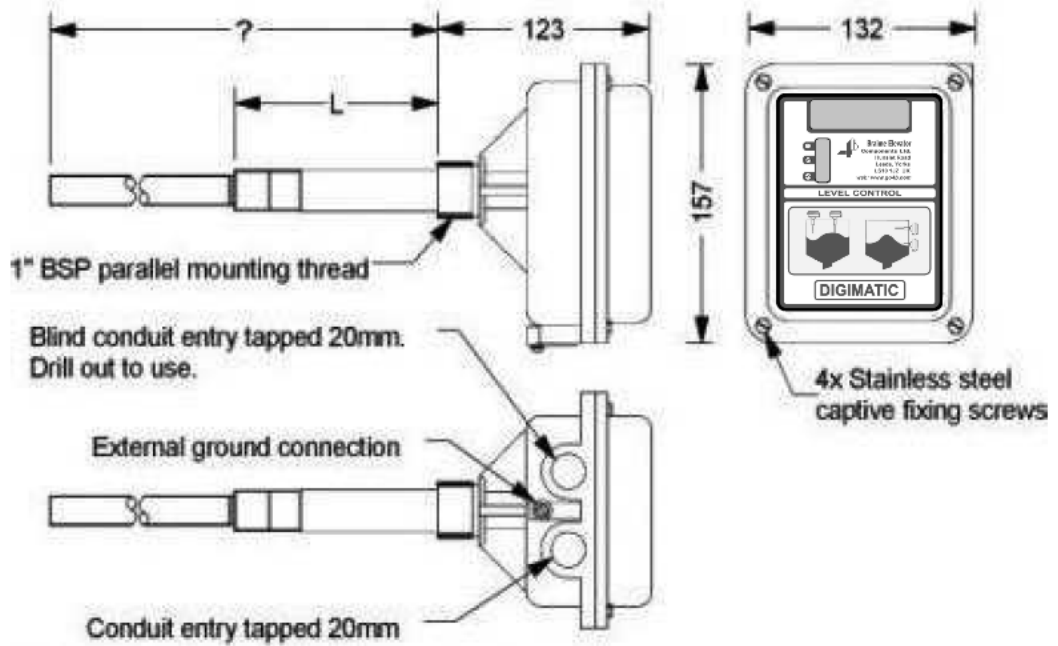

Powershield 'sleeve' to protrude as far as possible into vessel & not less than 6mm (1/4")

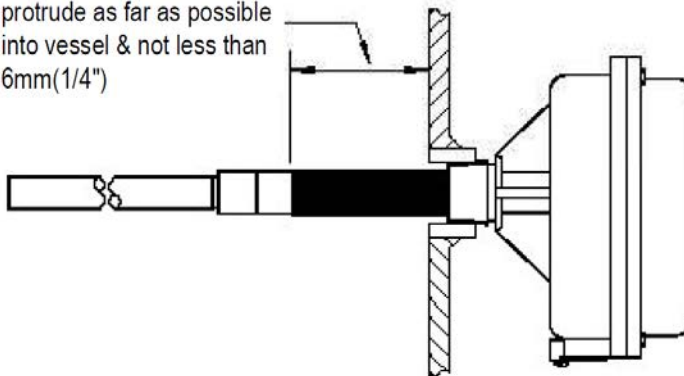

MOUNTING/POWERSHIELD DETAIL

ALL DIMENSIONS
IN MM

INSTALLATION

A thread locking compound is already applied to the probe fixing stud of the Digimatic. This will prevent the probe rod from vibrating loose. Once fitted, the compound is fully hardened after 20 minutes.

IMPORTANT: If the probe rod is removed from the unit for any reason, a thread locking compound must be applied before the rod is refitted.

When mounting all versions of the Digimatic, care must be taken to ensure that the power shield is properly installed.

DIGIMATIC will operate on 110V/230V ac 50/60Hz or 24V dc supplies. The unit may be wired in ordinary un-screened cable of any length and need not be separated from other cables.

A SUPPLY EARTH IS ESSENTIAL!

When mounting the DIGIMATIC, care must be taken to ensure that the exposed end of the power shield protrudes into the container.

Mount unit securely to minimise vibration. Connect in accordance with the standard wiring diagram, and set High/Low switch to required position (see below), ensure that cable gland and back cover are fully tightened when finished. The DIGIMATIC has two 20mm cable entries, one of which is blank, the blank may be drilled out carefully if required; it must not be knocked out.

The unit should be wired and earthed in accordance with appropriate Electrical Regulations. The unit must be earthed and the terminal **MUST** be bonded to the earth bond stud. On metal containers, unit earth **MUST** be bonded to the container. If the container is non-metallic, metal flanges or couplings used to mount probe should be bonded to earth. This also applies to probes mounted in wooden or plastic tops of metal bins.

Fail Safe Setting

The "High/Low" switch, sets the fail safe mode. In the "High" position, the relay is de-energised with material present. In the "Low" position, the relay is energised with material present. Normally, the "High" position is used for high level probes and the "Low" for low level probes. Intermediate probe settings depend upon individual requirements.

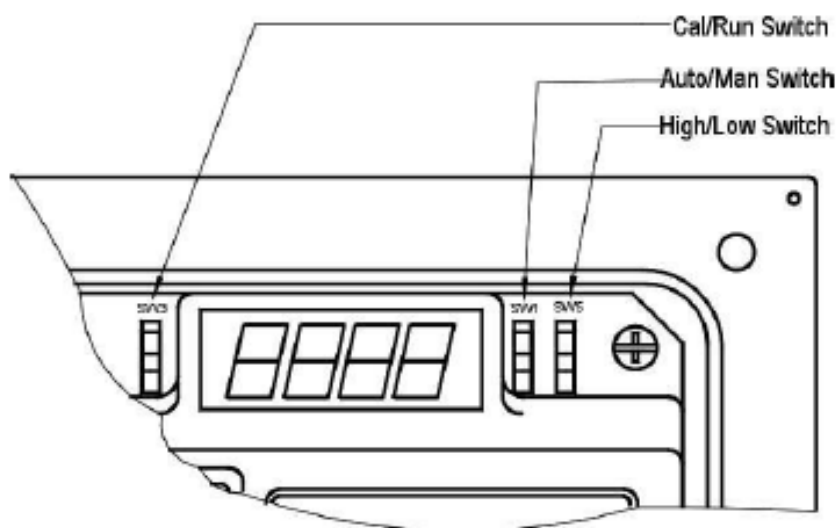

WARNING

Proper spacing of the power shield is vital for correct operation. For questions regarding proper spacing of the power shield to the vessel wall, contact 4B.

STANDARD WIRING DIAGRAM

All wiring must be in accordance with local and national electrical codes and should be undertaken by an experienced and qualified electrician.

A thread locking compound is already applied to the probe fixing stud of the DIGIMATIC. This will prevent the probe rod from vibrating loose. Once fitted, the compound is fully hardened after 20 minutes.

IMPORTANT: If the probe rod is removed from the unit for any reason, a thread locking compound must be applied before the rod is refitted.

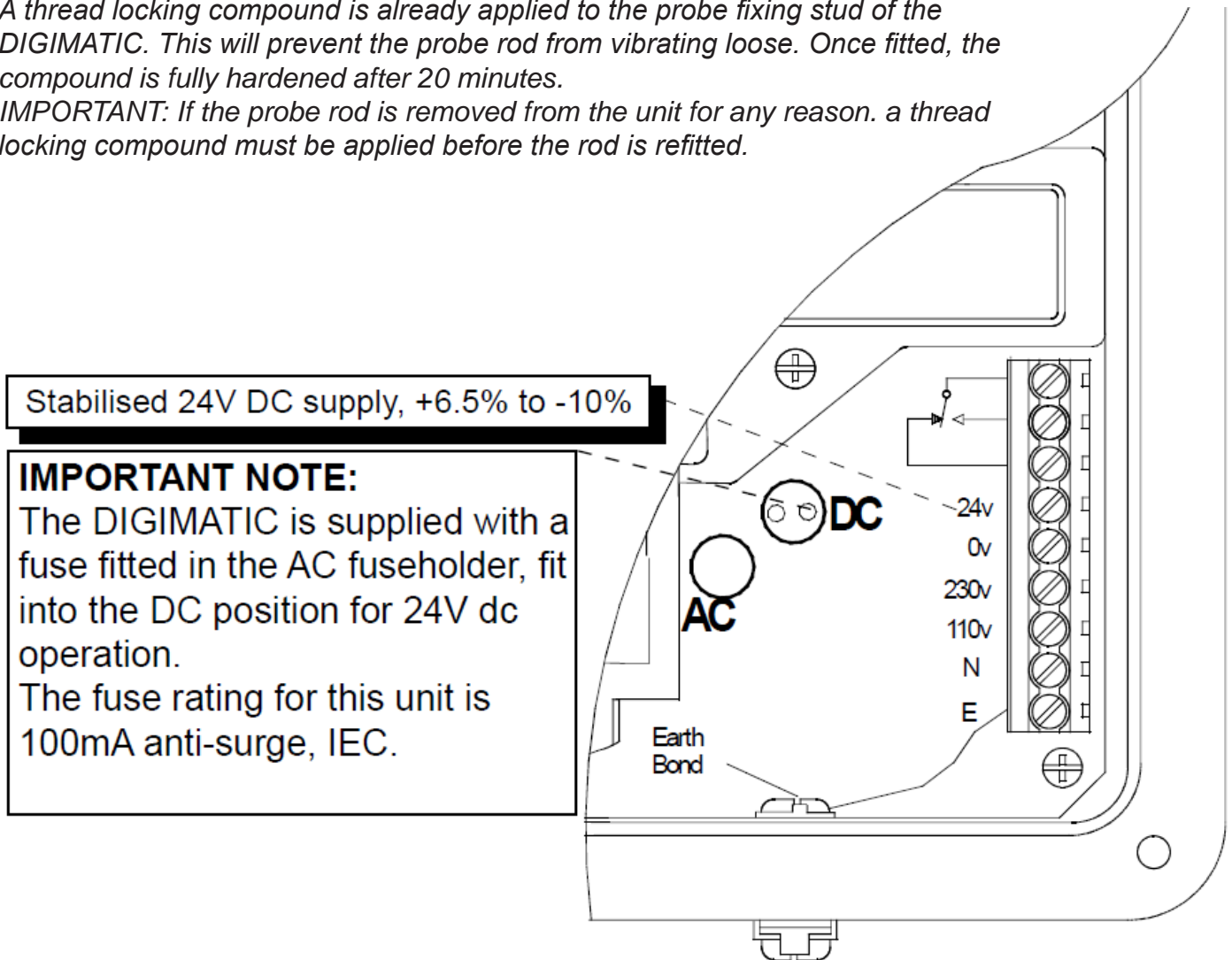
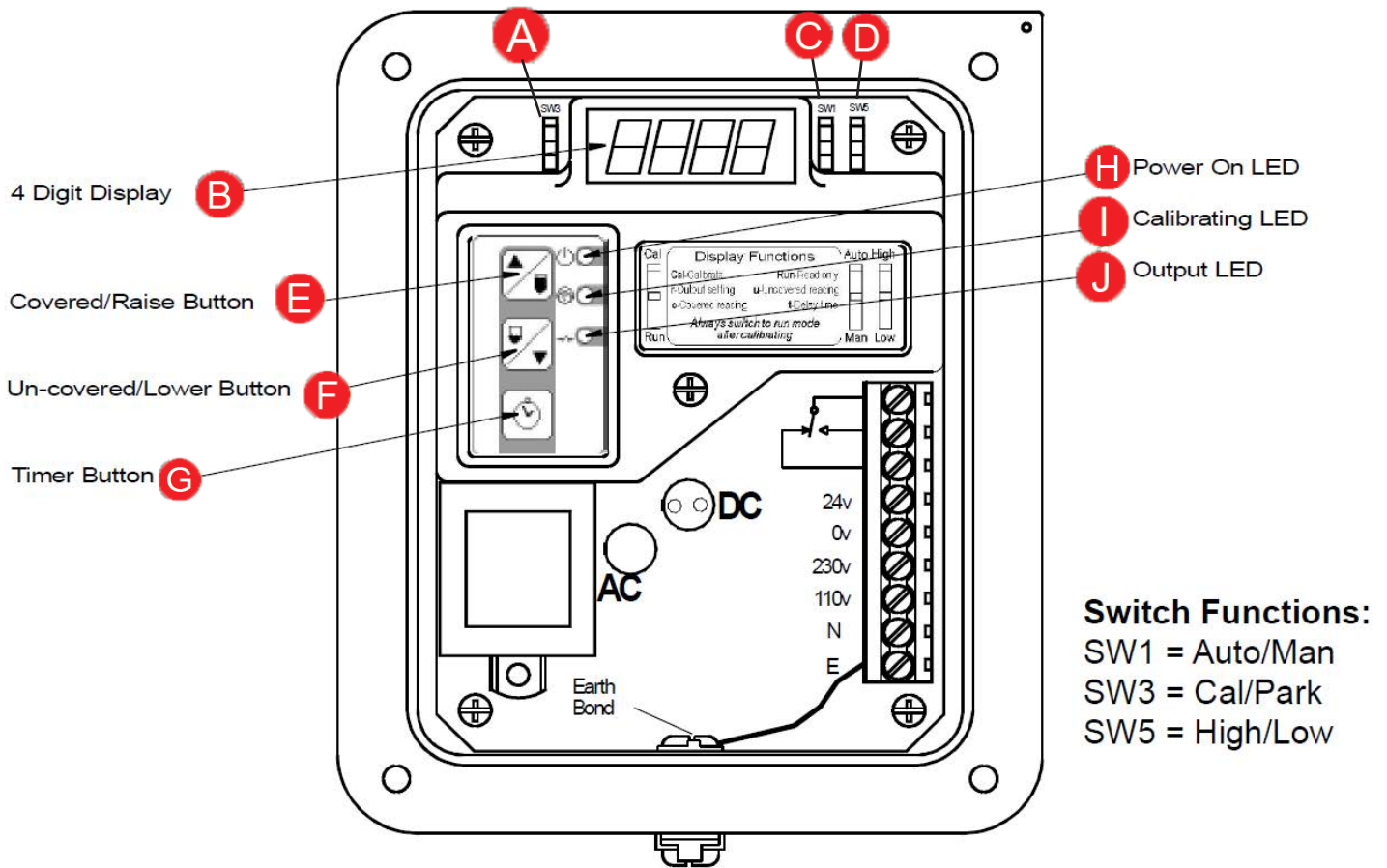

Image D



FAIL SAFE SETTING -

The “High/Low” switch (D - Image D), sets the fail safe mode. In the “High” position, the relay is energized without material present. In the “Low” position, the relay is energized with material present. Normally, the “High” position is used for high level probes and the “Low” position for low level probes. Intermediate probe settings depend upon individual requirements.

ELECTROSTATIC RISK - Ensure that the enclosure is not subject to charging in end application.

PARK MODE -

In normal operation, the LED display shows a value representing the capacitance measured by the probe at the time.



Pressing and holding the “Probe Covered / Raise” button (E - Image D) will cause the display to show CXXX followed by RXXX.



Pressing and holding the “Probe Un-Covered / Lower” button (F - Image D) will cause the display to show UXXX followed by RXXX.

CXXX is the probe covered value measured during calibration, UXXX is the uncovered value and RXXX is the relay operating point which the Auto-Set calculates and is half way between the two measured values.

NOTE

In park mode, settings are “View Only” and cannot be altered.

CAL MODE (AUTO/MAN SWITCH SET TO AUTO) -

 In this mode, pressing and holding the “Probe Covered / Raise” button (E - Image D) with the probe covered, will cause the unit to measure and display the covered value, and recalibrate the relay operating point if necessary.

 Pressing and holding the “Probe Un-Covered / Lower” button (F - Image D) with the probe uncovered, will cause the unit to measure and display the uncovered value, again recalibrating the relay operating point if necessary.

CAL MODE (AUTO/MAN SWITCH SET TO MAN) -

 In this mode, pressing and holding the “Probe Covered / Raise” button (E - Image D) will cause the display to momentarily display the present relay operating point and then to increment the setting slowly and then rapidly to set a higher operating point.

 Pressing and holding the “Probe Un-Covered / Lower” button (F - Image D) will cause the display to momentarily show the current relay operating point, and then decrement the setting, slowly and then rapidly.

Once adjusted in manual mode, any previous settings will be lost. The CXXX reading will be 1 above the relay operating point and the UXXX reading 1 below.

NOTE

Always return to “Park” after calibration.

SENSOR CALIBRATION

The Digimatic can be calibrated automatically, manually or by a combination of the two methods. Usually, automatic calibration is the simplest method, particularly when the vessel can be filled to cover the probe.

Manual calibration is useful when a number of probes in similar applications need to be set. Once the correct calibration has been determined and noted, on one system, the remainder can be set to the same setting.

AUTOMATIC CALIBRATION (MATERIAL AVAILABLE) -

1. Set Park/Cal switch (A - Image D) to Cal and Auto/Man switch (C - Image D) to Auto. The Cal LED will flash.
2. Ensure that the probe is uncovered and press and hold the “Probe Un-Covered / Lower” button (F - Image D) button. The display will show UXXX followed by RXXX.
3. Fill the vessel sufficiently to cover the probe and then press the “Probe Covered / Raise” button (E - Image D) button. Display will show CXXX followed by RXXX.
4. Return the Park/Cal switch (A - Image D) to park. The unit is now calibrated. UXXX and CXXX values can be viewed but not altered by pressing the “Probe Un-Covered / Lower” and “Probe Covered / Raise” buttons.



SEMI-AUTOMATIC CALIBRATION (MATERIAL NOT AVAILABLE) -

5. Follow steps 1 & 2 above.
6. Set Cal/Park switch (A - Image D) to Park and press the “Probe Un-Covered / Lower” button (F - Image D) button. Note the UXXX reading but ignore the RXXX reading. Return the Cal/Park switch (A - Image D) to Cal and set the Auto/Man switch (C - Image D) to Man.
7. From Table A below, select the nearest material type to be detected for your application and add the value to the UXXX reading determined in step 6.
8. Press the “Probe Covered / Raise” button (E - Image D) button to raise the reading and the “Probe Un-Covered / Lower” button (F - Image D) to lower the reading to achieve the calculated setting from step 7.
9. Return the Cal/Park switch (A - Image D) to Park and press and hold the “Probe Covered / Raise” button (E - Image D) to confirm that the relay operating point RXXX is correctly set. The UXXX and CXXX settings will be one below and one above the readings.



Table A - Typical Settings

Material Type	Increment
Light	+15
Medium	+30
Heavy	+60 or Greater

TIME DELAY -

The Auto-Set has an adjustable delay from 0 to 60 seconds, the timer operating on both material arriving and leaving.

To set the time delay, proceed as follows:

10. Set the Cal/Park switch (A - Image D) to Cal.



11. Press and hold the timer button (G - Image D), the display will show T000 (zero delay). To set a time delay, continue to hold the timer button and the display will start to increase by 1 second increments (maximum delay is 128 seconds). When the required delay time is shown, release the timer button. To reset the delay, press and hold the timer button again to restart the entire process from T000 (zero delay).



12. Return the Cal/Park switch (A - Image D) to Park and press the timer button (G - Image D) to confirm the timer setting.

13. The timer can be altered to a longer or shorter delay by repeating the entire procedure from steps 10 to 12.

NOTE

For questions regarding non-standard Digimatic probe lengths or diameters, contact 4B.

POWER SHIELD OVERVIEW

The Digimatic detects material by radiating a high frequency (RF) signal from the probe. The advanced electronics of the Digimatic use this signal to measure the capacitance inside the vessel with respect to ground and thus indicate when material has reached the Digimatic probe.

The power shield creates a barrier and enables the unit to ignore a certain amount of material built up on the probe, helping to prevent false readings. The Digimatic's standard power shield is 121mm in length, with options for a 160mm and 221mm available on request. Other specific lengths may be available. Please contact us for more information.

The standard (121 mm) power shield can be used with walls that are up to 115 mm (4.5 inches) thick. Installation through thick concrete silos only requires a 25.4 mm (1 inch) diameter hole for probe inser

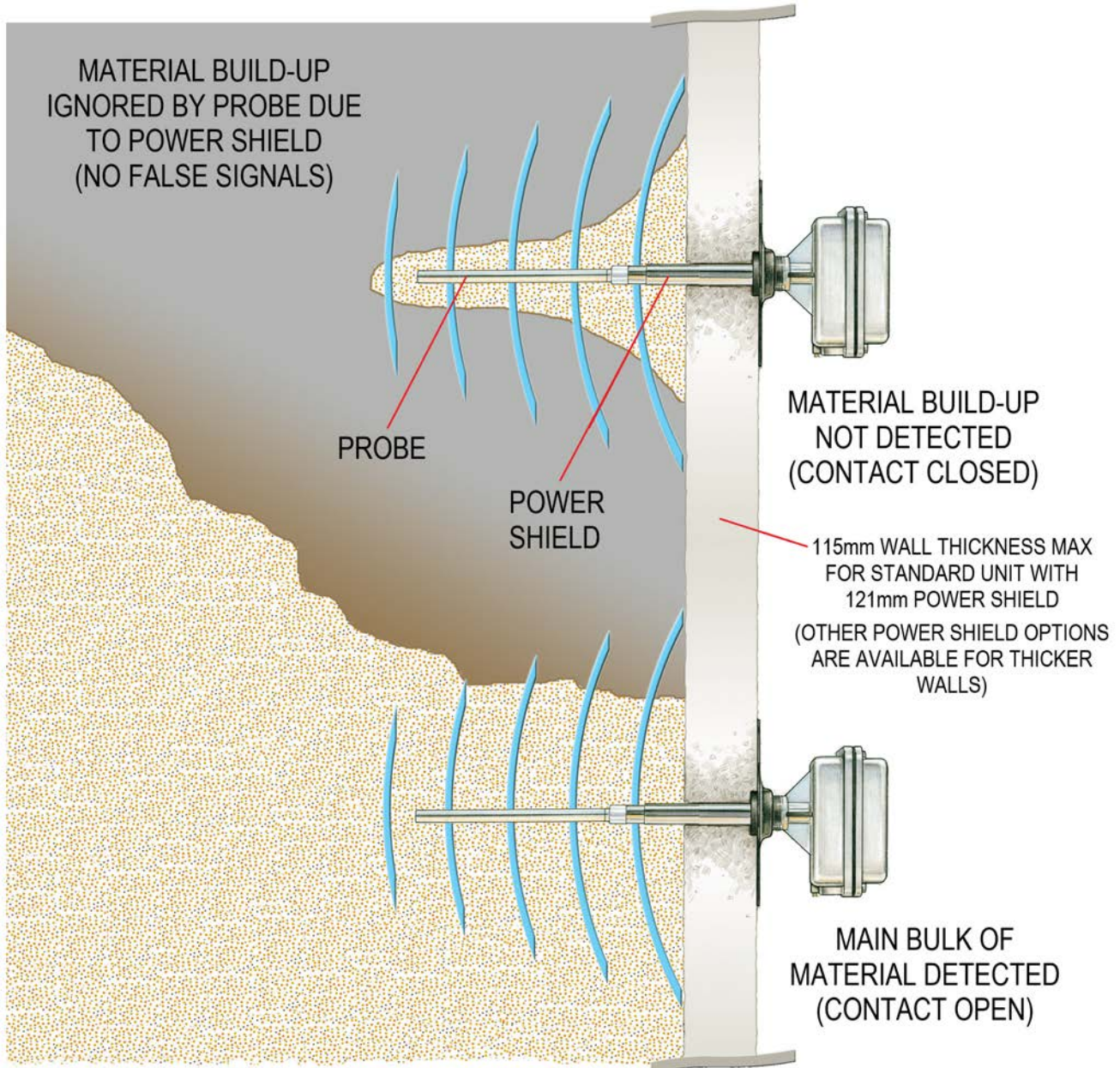

NOTE

The actual amount of material build up that the Digimatic is able to ignore is dependant upon several factors, including the density of the material, the moisture content of the material and the type/style of the vessel.

TESTING AND COMMISSIONING

1. Check that the unit is correctly installed (see standard wiring diagram).
2. After going through the sensor calibration steps, the green LED should be “ON”.
3. Introduce material to the Digimatic. If calibrated correctly, the Digimatic will activate when material has been detected. Machinery shut down will depend on your specific monitoring setup. 4B recommends an instant shutdown when maximum fill level or a plug condition has been detected.

WARNING

If the system does not immediately shutdown as expected or alarm as required, then remove the machine from service until the problem has been diagnosed and corrected.

TROUBLESHOOTING GUIDE

FAULT	REMEDY
Readings fluctuate when the weather changes.	Ground the Digimatic to the bin using the unit ground connection (Image C).
Relays operate backwards.	Verify that the “High/Low” switch is in the correct position (D - Image D).
Relay activates sporadically.	Set the timer delay to 1 or 2 seconds to ignore sporadic material issues.

Manufactured by SYNATEL Instrumentation Limited, WS11 9TB, UK

PARTS & ACCESSORIES

STAINLESS STEEL PROBES/WIRE

The Digimatic is available with 303 solid stainless steel probes. For applications up to 10 meter 33 feet long (maximum), 303 stainless steel wire is used to extend the probe length.

Probe	Length	Diameter
ATSP10*	220 mm	21 mm
ATSP11*	320 mm	16 mm
ATSP12*	1 m	16 mm
ATSP13*	2 m	16 mm
ATWP11	10 m	16 mm

**Note: Total length when fitted to DML4W. Actual loose probe length = stated length minus 120mm.*

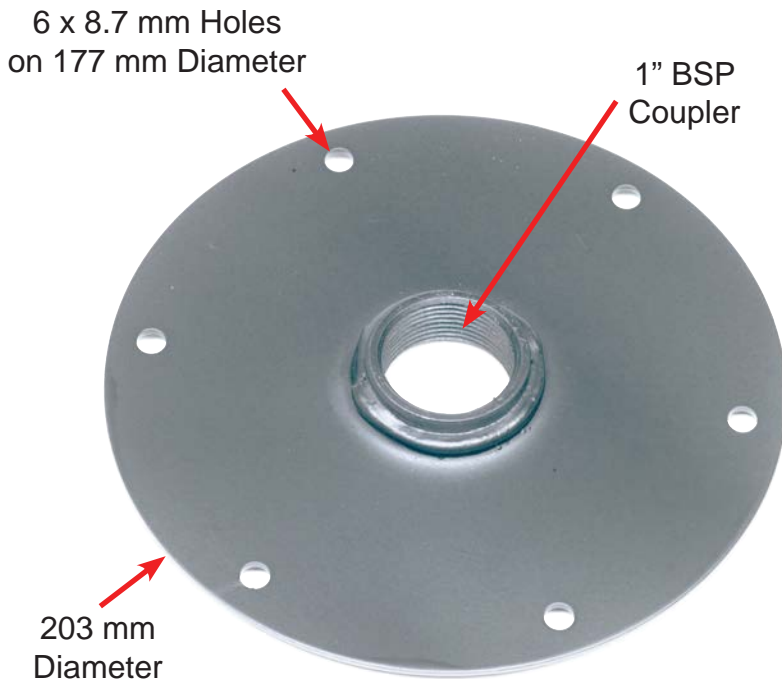

MOUNTING PLATE (SMP1)

The SMP is a zinc plated steel mounting plate for installing the Digimatic. A stainless steel version is also available.

ATSP10 ATSP11 ATSP12 ATSP13 ATWP11

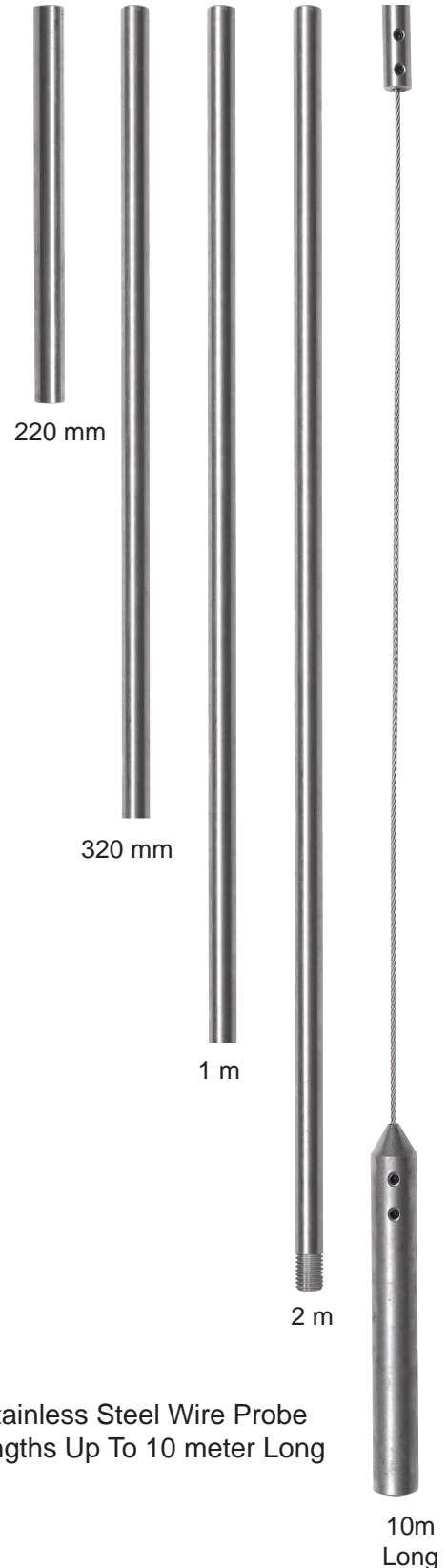

NOTE

These parts and accessories are not used with Auto-Set flush probe (ATS8V0AI-FP).

PRODUCT WARRANTY

1. EXCLUSIVE WRITTEN LIMITED WARRANTY

ALL PRODUCTS SOLD ARE WARRANTED BY THE COMPANY 4B COMPONENTS LIMITED AND 4B BRAIME COMPONENTS LIMITED HEREIN AFTER REFERRED TO AS 4B TO THE ORIGINAL PURCHASER AGAINST DEFECTS IN WORKMANSHIP OR MATERIALS UNDER NORMAL USE FOR ONE (1) YEAR AFTER DATE OF PURCHASE FROM 4B. ANY PRODUCT DETERMINED BY 4B AT ITS SOLE DISCRETION TO BE DEFECTIVE IN MATERIAL OR WORKMANSHIP AND RETURNED TO A 4B BRANCH OR AUTHORIZED SERVICE LOCATION, AS 4B DESIGNATES, SHIPPING COSTS PREPAID, WILL BE, AS THE EXCLUSIVE REMEDY, REPAIRED OR REPLACED AT 4B'S OPTION.

2. DISCLAIMER OF IMPLIED WARRANTY

NO WARRANTY OR AFFIRMATION OF FACT, EXPRESSED OR IMPLIED, OTHER THAN AS SET FORTH IN THE EXCLUSIVE WRITTEN LIMITED WARRANTY STATEMENT ABOVE IS MADE OR AUTHORIZED BY 4B. 4B SPECIFICALLY DISCLAIMS ANY LIABILITY FOR PRODUCT DEFECT CLAIMS THAT ARE DUE TO PRODUCT MISUSE, ABUSE OR MISAPPLICATIONS, AS AUTHORIZED BY LAW, 4B SPECIFICALLY DISCLAIMS ALL WARRANTIES THAT THE PRODUCT IS FIT OR MERCHANTABILITY FOR A PARTICULAR PURPOSE.

3. NO WARRANTY "BY SAMPLE OR EXAMPLE"

ALTHOUGH 4B HAS USED REASONABLE EFFORTS TO ACCURATELY ILLUSTRATE AND DESCRIBE THE PRODUCTS IN ITS CATALOGS, LITERATURE, AND WEBSITES, SUCH ILLUSTRATIONS AND DESCRIPTIONS ARE FOR THE SOLE PURPOSE OF PRODUCT IDENTIFICATION AND DO NOT EXPRESS OR IMPLY A WARRANTY AFFIRMATION OF FACT, OF ANY KIND OR A WARRANTY OR AFFIRMATION OF FACT THAT THE PRODUCTS WILL CONFORM TO THEIR RESPECTIVE ILLUSTRATIONS OR DESCRIPTIONS. 4B EXPRESSLY DISCLAIMS ANY WARRANTY OR AFFIRMATION OF FACT, EXPRESSED OR IMPLIED, OTHER THAN AS SET FORTH IN THE EXCLUSIVE WRITTEN LIMITED WARRANTY STATEMENT ABOVE, INCLUDING, WITHOUT LIMITATION, THE IMPLIED WARRANTIES OF MERCHANTABILITY AND FITNESS FOR A PARTICULAR PURPOSE.

4. LIMITATION OF DAMAGES

ANY LIABILITY FOR CONSEQUENTIAL, INCIDENTAL, SPECIAL, EXEMPLARY, OR PUNITIVE DAMAGES, OR FOR LOSS OF PROFIT WHETHER DIRECT OR INDIRECT, IS EXPRESSLY DISCLAIMED.

With subsidiaries in North America, Europe, China, Asia, Africa and Australia along with a worldwide network of distributors, 4B can provide practical solutions for all your applications no matter the location.



4B BRAIME COMPONENTS LTD.

Hunslet Road
Leeds
LS10 1JZ
United Kingdom
Tel: +44 (0) 113 246 1800
Email: 4b-uk@go4b.com

4B DEUTSCHLAND

35 Bis Rue Du 8 Mai 1945
80800 Villers, Bretonneux
France
Tel: +49 (0) 700 2242 4091
Email: 4b-deutschland@go4b.com

4B AFRICA

14 Newport Business Park
Mica Drive, Kya Sand
2163 Johannesburg
South Africa
Tel: +27 (0) 11 708 6114
Email: 4b-africa@go4b.com

4B FRANCE

35 Bis Rue Du 8 Mai 1945
80800 Villers, Bretonneux
France
Tel: +33 (0) 3 22 42 32 26
Email: 4b-france@go4b.com

4B COMPONENTS LTD.

625 Erie Avenue
Morton, IL 61550
USA
Tel: 309-698-5611
Fax: 309-698-5615

4B ASIA PACIFIC

Build No. 899/1 Moo 20
Soi Chongsiri, Bangplee-Tam
Ru Road, Tanbon Bangpleeyai,
Amphur Bangplee,
Samutprakarn 10540
Thailand
Tel: +66 (0) 2 173-4339
Email: 4b-asiapacific@go4b.com

4B China

F1, Building 5A,
Jintong Industrial Park,
8 West Lake Road,
Wujin High & New TDZ,
Changzhou, Jiangsu, PRC
Tel: +86-519-88556006
Email: 4b-china@go4b.com

4B AUSTRALIA

Building 1, 41 Bellrick Street
Acacia Ridge
Queensland 4110
Australia
Tel: +61 (0)7 3216 9365
Email: 4b-australia@go4b.com



www.go4b.com