



**WDA3V34CAI Motion & Alignment  
Sensor**

Congratulations on your purchase. 4B appreciates your business and is pleased you have chosen our products to meet your needs.

Please read in its entirety and understand the literature accompanying the product before you place the product into service. Please read the safety precautions carefully before operating the product. With each product you purchase from 4B, there are some basic but important safety considerations you must follow to be sure your purchase is permitted to perform its design function and operate properly and safely, giving you many years of reliable service. Please read and understand the Customer Safety Responsibilities listed below. Failure to follow this safety directive and the Operation Manuals and other material furnished or referenced, may result in serious injury or death.

***SAFETY NOTICE TO OUR CUSTOMERS***

- A. In order to maximize efficiency and safety, selecting the right equipment for each operation is vital. The proper installation of the equipment, and regular maintenance and inspection is equally important in continuing the proper operation and safety of the product. The proper installation and maintenance of all our products is the responsibility of the user unless you have asked 4B to perform these tasks.
- B. All installation and wiring must be in accordance with Local and National Electrical Codes and other standards applicable to your industry. (Please see the article "Hazard Monitoring Equipment Selection, Installation and Maintenance" at [www.go4b.com](http://www.go4b.com).) The installation of the wiring should be undertaken by an experienced and qualified professional electrician. Failure to correctly wire any product and/or machinery can result in the product or machine failing to operate as intended, and can defeat its design function.
- C. Periodic inspection by a qualified person will help assure your 4B product is performing properly. 4B recommends a documented inspection at least annually and more frequently under high use conditions.
- D. Please see the last page of this manual for all warranty information regarding this product.

***CUSTOMER SAFETY RESPONSIBILITIES***

**1. READ ALL LITERATURE PROVIDED WITH YOUR PRODUCT**

Please read all user, instruction and safety manuals to ensure that you understand your product operation and are able to safely and effectively use this product.

**2. YOU BEST UNDERSTAND YOUR NEEDS**

Every customer and operation is unique, and only you best know the specific needs and capabilities of your operation. Please call the 24-hour hotline at 309-698-5611 for assistance with any questions about the performance of products purchased from 4B. 4B is happy to discuss product performance with you at any time.

**3. SELECT A QUALIFIED AND COMPETENT INSTALLER**

Correct installation of the product is important for safety and performance. If you have not asked 4B to perform the installation of the unit on your behalf, it is critical for the safety of your operation and those who may perform work on your operation that you select a qualified and competent electrical installer to undertake the installation. The product must be installed properly to perform its designed functions. The installer should be qualified, trained, and competent to perform the installation in accordance with Local and National Electrical Codes, all relevant OSHA Regulations, as well as any of your own standards and preventive maintenance requirements, and

other product installation information supplied with the product. You should be prepared to provide the installer with all necessary installation information to assist in the installation.

#### **4. ESTABLISH AND FOLLOW A REGULAR MAINTENANCE AND INSPECTION SCHEDULE FOR YOUR 4B PRODUCTS**

You should develop a proper maintenance and inspection program to confirm that your system is in good working order at all times. You will be in the best position to determine the appropriate frequency for inspection. Many different factors known to the user will assist you in deciding the frequency of inspection. These factors may include but are not limited to weather conditions; construction work at the facility; hours of operation; animal or insect infestation; and the real-world experience of knowing how your employees perform their jobs. The personnel or person you select to install, operate, maintain, inspect or perform any work whatsoever, should be trained and qualified to perform these important functions. Complete and accurate records of the maintenance and inspection process should be created and retained by you at all times.

#### **5. RETAIN AND REFER TO THE OPERATION MANUAL FOR 4B'S SUGGESTED MAINTENANCE AND INSPECTION RECOMMENDATIONS**

As all operations are different, please understand that your specific operation may require additional adjustments in the maintenance and inspection process essential to permit the monitoring device to perform its intended function. Retain the Operation Manual and other important maintenance and service documents provided by 4B and have them readily available for people servicing your 4B equipment. Should you have any questions, please call the 4B location who supplied the product or the 24-hour hotline number in the USA -309-698-5611.

#### **6. SERVICE REQUEST AND ONLINE PRODUCT REGISTRATION**

If you have questions or comments about the operation of your unit or require the unit to be serviced please contact the 4B location who supplied the product or send your request via fax (309-698-5615), email (4b-usa@go4b.com), or call us via our 24-hour hotline number in the USA - 309-698-5611. Please have available product part numbers, serial numbers, and approximate date of installation. In order to assist you, after the product has been placed into service, complete the Online Product Registration section which is accessed via our website [www.go4b.com](http://www.go4b.com)



# WDA3V34CAI

## MOTION ALIGNMENT SENSOR

### DESCRIPTION

The WDA3 sensor detects moving ferrous material and is designed for use with bucket elevators and conveyors to detect the buckets, for measurement of speed and alignment. It can also detect ferrous bolts, which are used to attach non-ferrous buckets. The sensor is used in conjunction with a PLC or with a Watchdog or A400 Elite control unit. Two output signals are provided: one signal is a pulse output, representing each bucket detected: the second signal is a continuous output when moving buckets are detected.

### SPECIFICATION

Model No	WDA3V34CAI	
Voltage	12-24vdc $\pm$ 10%	
Supply current	25-65ma	
Outputs (max)	100ma Sink (Pull) 50ma Source (Push)	
Detection range (1" bolt head)	25mm-75mm	1" – 3"
Detection rate	20-2000/min	
Protection	IP66	
Hazardous area classification	See protection below	
Dimensions	50mm DIA x 150mm	2" DIA. x 5 3/4 "
Fixing centres, M6	See supplied Template	
Cable	6 core 3m long	6 core 9ft long
Conduit entry	1/2" NPT	
Weight (shipping weight)	500g	1.1lb

### CABLE CONNECTIONS

RED	+ve supply 12-24v dc $\pm$ 10%
BLACK	-ve supply Ov
GREEN	Earth (Ground) Connected to case
YELLOW/ORANGE	Control 0 - +ve supply
BLUE	Pulsed output, normally low, high when detecting
WHITE	Continuous output, normally high, low when detecting

### PROTECTION.

Ex II 1D T120°C – CE1180 Baseefa 05ATEX 0088X : IECEX DIP DIP A20 TA120°C – IECEX BAS 05.0031X  
Ex II 2D T80°C – CE1180 Baseefa 05ATEX 0089X : IECEX DIP DIP A21 TA80°C – IECEX BAS 05.0032X  
Tamb -20°C to +50°C IP66  
CSA Class II Division 1 Groups E, F & G

When installed as category 1D or 2D equipment adequate cleaning must ensure dust layers are kept below 5mm or 1/5"

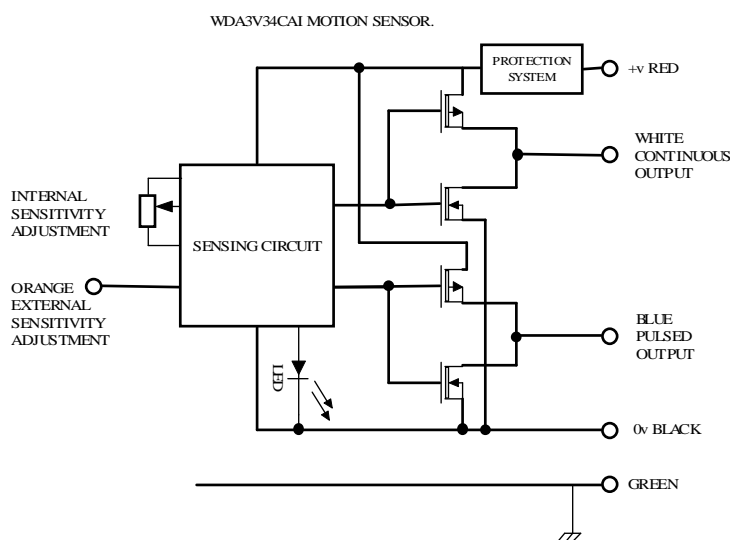

## **CONTROL**

Sensitivity adjustment is achieved with the internal potentiometer and the voltage on the YELLOW/ORANGE wire.

To use the internal potentiometer only (as with the Watchdog) connect the YELLOW/ORANGE wire to the RED wire (+ve, 12-24v). Turn the potentiometer clockwise to increase sensitivity.

To use the external control voltages (as with the A400) connect the YELLOW/ORANGE wire to the control voltage from the A400 and turn the potentiometer on the WDA3 fully anti-clockwise. Reduce the control voltage to increase sensitivity.

In both arrangements, reduce the sensitivity if the pulsed output (LED) becomes unstable.

## **LED INDICATOR**

The green LED shows the state of the pulsed output and flashes once for each bucket (bolt) detected. The LED should be off when no buckets (bolts) are detected, if not, reduce the sensitivity.

### **Installation:**

- a. The IP66 rating of the enclosure must be maintained when used in Zone 20 and 21 dust environment.
- b. You may optionally use an apparatus certified gland for cable strain relief but the gland and sealing arrangement must be in accordance with the installation codes detailed in BS EN 60079 and EN 50281 or the NATIONAL ELECTRICAL CODES.
- c. Where other certified components are used as part of the assembly or installation procedure, the user must take in to account any limitations which might be listed on the relevant certificates.
- d. The enclosure must not be modified in any way without reference to the manufacturer, as this will invalidate the certification.
- e. All wiring must be carried out in accordance with relevant national codes of practice and / or instructions (BS EN 600079-14, EN50281).
- f. The voltage and current and maximum power dissipation shown on the label must not be exceeded.

## MOUNTING

When mounting on a steel elevator leg cut a hole 55mm or 2 1/8" diameter and fix with the mounting block provided. The depth of the sensor penetration can be adjusted by slackening the clamp cross bolt and sliding the sensor in or out to the required depth. Final sensitivity adjustment should be made using the integrated adjustment or via the orange wire.

### Electrical connections:

RED	+Ve Supply, 12-24 vdc $\pm$ 10%
BLACK	- Ve Supply 0v
GREEN	Earth (ground) Connected to case
YELLOW/ORANGE	Control signal 0V to +Ve
BLUE	Pulsed output, normally low, high when detecting
WHITE	Continuous output, normally high, low when detecting

### Cable colour comparison.

#### **WDA3** (Steel body)

RED  
BLACK  
GREEN  
BLUE  
WHITE  
YELLOW/ORANGE

Note: The WDA3V34AI contains a non repairable 160mA fuse and two thermal fuses set at 73°C (164°F). Should the body of the sensor reach 73°C (164°F) or higher then one or both of the thermal fuses may fail. The expected maximum ambient for this sensor is +50°C (122°F).

CONTACT DETAIL:



[www.go4b.com](http://www.go4b.com)

## **WARRANTY INFORMATION**

### **1. EXCLUSIVE WRITTEN LIMITED WARRANTY**

ALL PRODUCTS SOLD ARE WARRANTED BY THE COMPANY (4B COMPONENTS LIMITED, (4B) BRAIME ELEVATOR COMPONENTS LIMITED, AND (4B) S.E.T.E.M. Srl) HEREIN AFTER REFERRED TO AS 4B TO THE ORIGINAL PURCHASER AGAINST DEFECTS IN WORKMANSHIP OR MATERIALS UNDER NORMAL USE FOR ONE (1) YEAR AFTER DATE OF PURCHASE FROM 4B. ANY PRODUCT DETERMINED BY 4B AT ITS SOLE DISCRETION TO BE DEFECTIVE IN MATERIAL OR WORKMANSHIP AND RETURNED TO A 4B BRANCH OR AUTHORIZED SERVICE LOCATION, AS 4B DESIGNATES, SHIPPING COSTS PREPAID, WILL BE, AS THE EXCLUSIVE REMEDY, REPAIRED OR REPLACED AT 4B'S OPTION.

### **2. DISCLAIMER OF IMPLIED WARRANTY**

NO WARRANTY OR AFFIRMATION OF FACT, EXPRESSED OR IMPLIED, OTHER THAN AS SET FORTH IN THE EXCLUSIVE WRITTEN LIMITED WARRANTY STATEMENT ABOVE IS MADE OR AUTHORIZED BY 4B. 4B SPECIFICALLY DISCLAIMS ANY LIABILITY FOR PRODUCT DEFECT CLAIMS THAT ARE DUE TO PRODUCT MISUSE, ABUSE OR MISAPPLICATIONS, AS AUTHORIZED BY LAW, 4B SPECIFICALLY DISCLAIMS ALL WARRANTIES THAT THE PRODUCT IS FIT OR MERCHANTABLE FOR A PARTICULAR PURPOSE.

### **3. NO WARRANTY "BY SAMPLE OR EXAMPLE"**

ALTHOUGH 4B HAS USED REASONABLE EFFORTS TO ACCURATELY ILLUSTRATE AND DESCRIBE THE PRODUCTS IN ITS CATALOGS, LITERATURE, AND WEBSITES, SUCH ILLUSTRATIONS AND DESCRIPTIONS ARE FOR THE SOLE PURPOSE OF PRODUCT IDENTIFICATION AND DO NOT EXPRESS OR IMPLY A WARRANTY AFFIRMATION OF FACT, OF ANY KIND OR A WARRANTY OR AFFIRMATION OF FACT THAT THE PRODUCTS WILL CONFORM TO THEIR RESPECTIVE ILLUSTRATIONS OR DESCRIPTIONS. 4B EXPRESSLY DISCLAIMS ANY WARRANTY OR AFFIRMATION OF FACT, EXPRESSED OR IMPLIED, OTHER THAN AS SET FORTH IN THE EXCLUSIVE WRITTEN LIMITED WARRANTY STATEMENT ABOVE, INCLUDING, WITHOUT LIMITATION, THE IMPLIED WARRANTIES OF MERCHANTABILITY AND FITNESS FOR A PARTICULAR PURPOSE.

### **4. LIMITATION OF DAMAGES**

ANY LIABILITY FOR CONSEQUENTIAL, INCIDENTAL, SPECIAL, EXEMPLARY, OR PUNITIVE DAMAGES, OR FOR LOSS OF PROFIT WHETHER DIRECT OR INDIRECT, IS EXPRESSLY DISCLAIMED.

Document Revision	Date revised	Revisions made
R1.7	Sept /2009	Added legal and warranty information to the manual
R1.8	Jan/2010	Updated the legal and warranty information. Removed CSA from the certification details.
R2	March 2011	CSA certification added.
R3	May 2011	Removal of D of C (now supplied separately)
R4	Nov 2011	Updated Specification