

TouchSwitch™

US Patent # 6,731,219

Other Patents Pending

Installation and Set-Up



TS2V4CAI & TS2V3CAI



Technology • Innovation • Quality • Value

www.go4b.com

Issue: 0 June 2014

Dear 4B Customer:

Congratulations on your purchase. 4B appreciates your business and is pleased you have chosen our products to meet your needs.

Please read in its entirety and understand the literature accompanying the product before you place the product into service. Please read the safety precautions carefully before operating the product. With each product you purchase from 4B, there are some basic but important safety considerations you must follow to be sure your purchase is permitted to perform its design function and operate properly and safely, giving you many years of reliable service. Please read and understand the Customer Safety Responsibilities listed below. Failure to follow this safety directive and the Operation Manuals and other material furnished or referenced, may result in serious injury or death.

SAFETY NOTICE TO OUR CUSTOMERS

- A. In order to maximize efficiency and safety, selecting the right equipment for each operation is vital. The proper installation of the equipment, and regular maintenance and inspection is equally important in continuing the proper operation and safety of the product. The proper installation and maintenance of all our products is the responsibility of the user unless you have asked 4B to perform these tasks.
- B. All installation and wiring must be in accordance with Local and National Electrical Codes and other standards applicable to your industry. (Please see the article "Hazard Monitoring Equipment Selection, Installation and Maintenance" at www.go4b.com.) The installation of the wiring should be undertaken by an experienced and qualified professional electrician. Failure to correctly wire any product and/or machinery can result in the product or machine failing to operate as intended, and can defeat its design function.
- C. Periodic inspection by a qualified person will help assure your 4B product is performing properly. 4B recommends a documented inspection at least annually and more frequently under high use conditions.
- D. Please see the last page of this manual for all warranty information regarding this product.

CUSTOMER SAFETY RESPONSIBILITIES

1. READ ALL LITERATURE PROVIDED WITH YOUR PRODUCT

Please read all user, instruction and safety manuals to ensure that you understand your product operation and are able to safely and effectively use this product.

2. YOU BEST UNDERSTAND YOUR NEEDS

Every customer and operation is unique, and only you best know the specific needs and capabilities of your operation. Please call the 24-hour hotline at 309-698-5611 for assistance with any questions about the performance of products purchased from 4B. 4B is happy to discuss product performance with you at any time.

3. SELECT A QUALIFIED AND COMPETENT INSTALLER

Technology ♦ Innovation ♦ Quality ♦ Value

www.go4b.com

Issue:0 June 2014

Correct installation of the product is important for safety and performance. If you have not asked 4B to perform the installation of the unit on your behalf, it is critical for the safety of your operation and those who may perform work on your operation that you select a qualified and competent electrical installer to undertake the installation. The product must be installed properly to perform its designed functions. The installer should be qualified, trained, and competent to perform the installation in accordance with Local and National Electrical Codes, all relevant OSHA Regulations, as well as any of your own standards and preventive maintenance requirements, and other product installation information supplied with the product. You should be prepared to provide the installer with all necessary installation information to assist in the installation.

4. ESTABLISH AND FOLLOW A REGULAR MAINTENANCE AND INSPECTION SCHEDULE FOR YOUR 4B PRODUCTS

You should develop a proper maintenance and inspection program to confirm that your system is in good working order at all times. You will be in the best position to determine the appropriate frequency for inspection. Many different factors known to the user will assist you in deciding the frequency of inspection. These factors may include but are not limited to weather conditions; construction work at the facility; hours of operation; animal or insect infestation; and the real-world experience of knowing how your employees perform their jobs. The personnel or person you select to install, operate, maintain, inspect or perform any work whatsoever, should be trained and qualified to perform these important functions. Complete and accurate records of the maintenance and inspection process should be created and retained by you at all times.

5. RETAIN AND REFER TO THE OPERATION MANUAL FOR 4B'S SUGGESTED MAINTENANCE AND INSPECTION RECOMMENDATIONS

As all operations are different, please understand that your specific operation may require additional adjustments in the maintenance and inspection process essential to permit the monitoring device to perform its intended function. Retain the Operation Manual and other important maintenance and service documents provided by 4B and have them readily available for people servicing your 4B equipment. Should you have any questions, please call the 4B location who supplied the product or the 24-hour hotline number in the USA -309-698-5611.

6. SERVICE REQUEST AND ONLINE PRODUCT REGISTRATION

If you have questions or comments about the operation of your unit or require the unit to be serviced please contact the 4B location who supplied the product or send your request via fax (309-698-5615), email (4b-usa@go4b.com), or call us via our 24-hour hotline number in the USA - 309-698-5611. Please have available product part numbers, serial numbers, and approximate date of installation. In order to assist you, after the product has been placed into service, complete the Online Product Registration section which is accessed via our website www.go4b.com

Technology ♦ Innovation ♦ Quality ♦ Value

www.go4b.com

Issue:0 June 2014

TouchSwitch™ Installation and Set-Up



Introduction:

The **TouchSwitch™** from 4B is an electronic limit switch with no moving parts. When a belt misaligns or a pulley moves over and contacts the sensor, the built in solid-state electronic circuitry detects the lateral force of the belt or pulley and activates a voltage free relay contact. This relay contact is used to immediately alarm and shutdown the machine. The face of the sensor is made from hardened stainless steel, so that there is no wear when a belt contacts it. The sensor is not affected by dust or material build up and will still work when completely covered by material. Sensors are normally installed in pairs on opposite sides of the machine. Usually a pair of sensors at each pulley is used, but additional pairs can be installed as required. An external test knob allows for quick and simple sensor / system testing.

Installation:

Warning: Always lock-out and tag-out the machine prior to installation and set-up.

Mark a location on the outside of the machines casing where the misaligned belt or pulley would contact the center of the stainless steel sensing face. At this location drill a 55mm diameter hole through the machines casing. With the sensor centred on this hole and the conduit entry pointing down, mark the four fixing holes (equally spaced on 73.7mm diameter). Ensure that the rubber gasket is in place and mount the sensor using screws, bolts or studs. (If required, use the additional plastic spacers provided to reduce the distance that the sensor face protrudes into the casing). If the casing material allows, mounting holes can be drilled and tapped for M5 screws, allowing sensor installation and removal from the outside. However, make sure that the mounting screws do not protrude through the machine casing where they could come in contact with the belt.

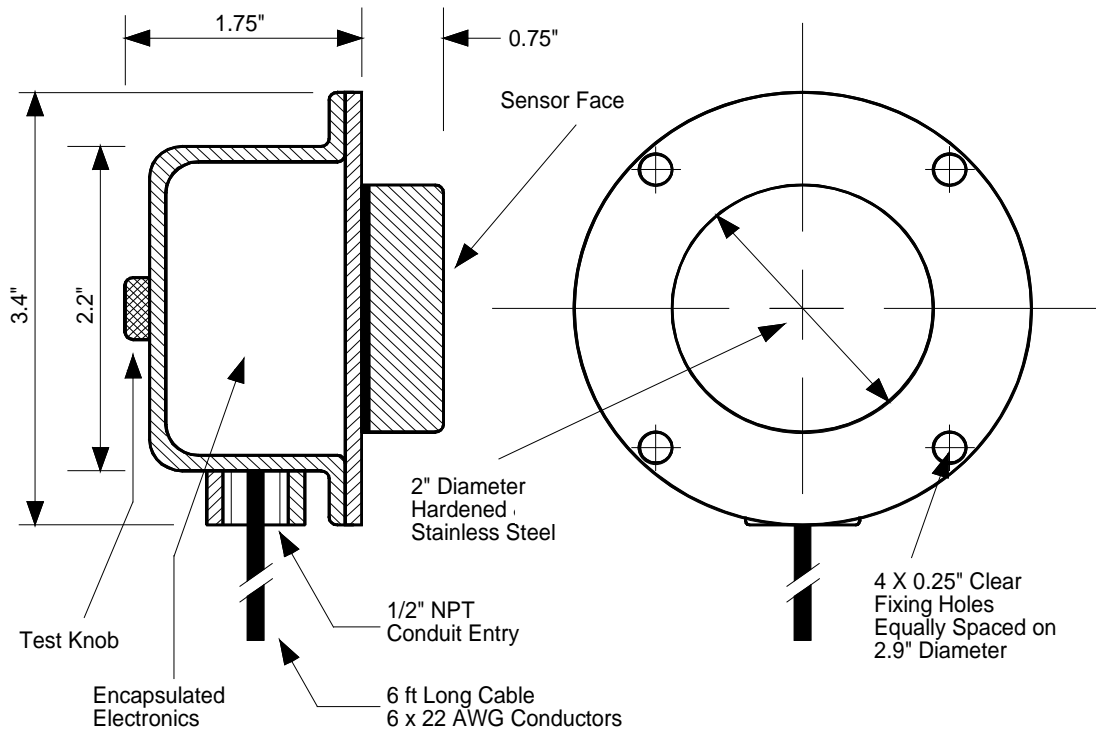

Technology • Innovation • Quality • Value

www.go4b.com

Issue:0 June 2014



Specification:

Supply Voltage:	12 vdc (TS2V3CAI)	24 vdc (TS2V4CAI)
Power Consumption:	60mA	50mA
Indication:	Red LED indicates when powered up and relay is energized.	
Adjustment:	Force Sensitivity is factory set to 8 lb (3.6 Kg) approx.	
Output:	Voltage free changeover relay contact rated at 5A 250vac Non-inductive.	
Body Construction:	Pressed seamless steel, powder coated.	
Face Construction:	Hardened stainless steel.	
Conduit Entry:	½" NPT	
Cable Length:	9ft (3M)	
Conductors:	6 at 22awg (see "wiring" below)	
Weight:	3 lb (1.36 Kg)	
Approvals /	Class II Div. 1 Groups E, F, & G approved (US and Canada) Ex II 2 D Ex tb IIIC T80°C Db IP66 Baseefa14ATEX0015X, IECEx BAS 13.0116X	
Protection:	NEMA 4X, IP 66	
Dimensions:	3.5" Diameter x 1.75" Deep (see diagram above)	

Specific Conditions of use :

1. Do not allow dust layers to build up on this product.
2. The sensors/switches shall be connected to a suitable external earth via the mounting arrangement or via the flange mounting screws and suitable ring crimp lug and accessories.
3. The integral cable shall be terminated in a suitably certified enclosure or in the safe area.

Wiring:

All Wiring Must Be In Accordance With Local And National Electrical Codes And Should Be Undertaken By An Experienced And Professional, Qualified Electrician.

Mount a suitable junction box within 3m of the sensor, and using a suitable conduit to protect the cables, make the necessary wiring connections inside this junction box. A 3m long PVC coated cable connected to the sensor contains the following 22 AWG wires:

Red	+12 vdc (TS2V3C)	+24 vdc (TS2V4C)
Black	0 vdc	
Green	Ground	
White	Relay Common Connection	
Blue	Relay Contact, N.O.	
Orange	Relay Contact, N.C.	

Note: The TouchSwitch contains a non repairable 160mA fuse and thermal fuses set at 73°C. Should the body of the sensor reach 73°C or higher then the thermal fuses may fail.

Note: The relay contact is energized when power is supplied to the sensor and de-energizes when the sensor detects the belt or pulley. Relay contact closed between White and Blue when unit is powered and Led is on "Red" LED on: indicates power and relay energized.

"Red" LED off: indicates relay de-energized and/or no power.

Technology • Innovation • Quality • Value

www.go4b.com

Issue:0 June 2014

WARNINGS

TouchSwitch Wiring is Low Voltage DC

Use shielded cable and keep separate from high voltage cables

Never run TouchSwitch cables in the same conduit as 3-phase motor cables

Never weld near or around the TouchSwitch

Track belts and commission plant prior to installing Touchswitches.

Set-up and Test:

Observe that the red LED on the sensor housing is on and the belt or pulley is not touching the sensor. Slowly turn the test knob clockwise by hand, until the LED goes out. Check that alarms and shutdowns work as expected. Turn the test knob back to its original position. Observe that the LED is now on.

Periodically test the sensor and system, and visually inspect the contact surface of the sensor.

WARRANTY INFORMATION

1. EXCLUSIVE WRITTEN LIMITED WARRANTY

ALL PRODUCTS SOLD ARE WARRANTED BY THE COMPANY (4B COMPONENTS LIMITED, (4B) BRAIME ELEVATOR COMPONENTS LIMITED, AND (4B) S.E.T.E.M. Sarl) HEREIN AFTER REFERRED TO AS 4B TO THE ORIGINAL PURCHASER AGAINST DEFECTS IN WORKMANSHIP OR MATERIALS UNDER NORMAL USE FOR ONE (1) YEAR AFTER DATE OF PURCHASE FROM 4B. ANY PRODUCT DETERMINED BY 4B AT ITS SOLE DISCRETION TO BE DEFECTIVE IN MATERIAL OR WORKMANSHIP AND RETURNED TO A 4B BRANCH OR AUTHORIZED SERVICE LOCATION, AS 4B DESIGNATES, SHIPPING COSTS PREPAID, WILL BE, AS THE EXCLUSIVE REMEDY, REPAIRED OR REPLACED AT 4B'S OPTION.

2. DISCLAIMER OF IMPLIED WARRANTY

NO WARRANTY OR AFFIRMATION OF FACT, EXPRESSED OR IMPLIED, OTHER THAN AS SET FORTH IN THE EXCLUSIVE WRITTEN LIMITED WARRANTY STATEMENT ABOVE IS MADE OR AUTHORIZED BY 4B. 4B SPECIFICALLY DISCLAIMS ANY LIABILITY FOR PRODUCT DEFECT CLAIMS THAT ARE DUE TO PRODUCT MISUSE, ABUSE OR MISAPPLICATIONS, AS AUTHORIZED BY LAW, 4B SPECIFICALLY DISCLAIMS ALL WARRANTIES THAT THE PRODUCT IS FIT OR MERCHANTABLE FOR A PARTICULAR PURPOSE.

3. NO WARRANTY "BY SAMPLE OR EXAMPLE"

ALTHOUGH 4B HAS USED REASONABLE EFFORTS TO ACCURATELY ILLUSTRATE AND DESCRIBE THE PRODUCTS IN ITS CATALOGS, LITERATURE, AND WEBSITES, SUCH ILLUSTRATIONS AND DESCRIPTIONS ARE FOR THE SOLE PURPOSE OF PRODUCT IDENTIFICATION AND DO NOT EXPRESS OR IMPLY A WARRANTY AFFIRMATION OF FACT, OF ANY KIND OR A WARRANTY OR AFFIRMATION OF FACT THAT THE PRODUCTS WILL CONFORM TO THEIR RESPECTIVE ILLUSTRATIONS OR DESCRIPTIONS. 4B EXPRESSLY DISCLAIMS ANY WARRANTY OR AFFIRMATION OF FACT, EXPRESSED OR IMPLIED, OTHER THAN AS SET FORTH IN THE EXCLUSIVE WRITTEN LIMITED WARRANTY STATEMENT ABOVE, INCLUDING, WITHOUT LIMITATION, THE IMPLIED WARRANTIES OF MERCHANTABILITY AND FITNESS FOR A PARTICULAR PURPOSE.

4. LIMITATION OF DAMAGES

ANY LIABILITY FOR CONSEQUENTIAL, INCIDENTAL, SPECIAL, EXEMPLARY, OR PUNITIVE DAMAGES, OR FOR LOSS OF PROFIT WHETHER DIRECT OR INDIRECT, IS EXPRESSLY DISCLAIMED.

Technology ♦ Innovation ♦ Quality ♦ Value

www.go4b.com

Issue:0 June 2014

Document Revision	Date revised	Revisions made
Issue 0	09.06.2014	Zn21/cat2d version created (based on Old Zn20/Cat1D issue2 july '13