

# INSTRUCTION MANUAL



Approvals



## **Milli-Con** 4-20 mA Vibration Transmitter

Part Number: VIBMIL\*\*\*V\*\*

REV011025



- EN** To download the digital version of this instruction manual and to check other available languages scan the following QR code.
- ES** Para descargar la versión digital de este manual de instrucciones y consultar otros idiomas disponibles, escanee el siguiente código QR.
- PT** Para baixar a versão digital deste manual de instruções e verificar outros idiomas disponíveis, escaneie o seguinte código QR.
- FR** Pour télécharger la version numérique de ce manuel d'instructions et pour vérifier les autres langues disponibles, scannez le code QR suivant.
- DE** Um die digitale Version dieser Bedienungsanleitung herunterzuladen und andere verfügbare Sprachen zu überprüfen, scannen Sie den folgenden QR-Code.
- RU** Чтобы загрузить цифровую версию данного руководства по эксплуатации и проверить другие доступные языки, отсканируйте следующий QR-код.
- ZH** 要下載本說明手冊的數字版本並查看其他可用語言，請掃描以下二維碼。



## TABLE OF CONTENTS

---

CUSTOMER SAFETY RESPONSIBILITIES .....	4
PRODUCT OVERVIEW .....	7
PACKAGE CONTENT .....	7
SPECIFICATIONS .....	7
APPROVALS.....	8
DIMENSIONS .....	8
SPECIFIC CONDITIONS OF USE.....	9
STANDARD WIRING DIAGRAM .....	9
INSTALLATION .....	10
TESTING AND MAINTENANCE.....	10
PRODUCT WARRANTY .....	15

## CUSTOMER SAFETY RESPONSIBILITIES

---

4B appreciates your business and is pleased you have chosen our products to meet your needs.

Please read in its entirety and understand the literature accompanying the product before you place the product into service. Please read the safety precautions carefully before operating the product. With each product you purchase from 4B, there are some basic but important safety considerations you must follow to be sure your purchase is permitted to perform its design function and operate properly and safely, giving you many years of reliable service. Please read and understand the Customer Safety Responsibilities listed below. Failure to follow this safety directive and the Operation Manuals and other material furnished or referenced, may result in serious injury or death.

### **SAFETY NOTICE TO OUR CUSTOMERS**

- A. In order to maximize efficiency and safety, selecting the right equipment for each operation is vital. The proper installation of the equipment, and regular maintenance and inspection is equally important in continuing the proper operation and safety of the product. The proper installation and maintenance of all our products is the responsibility of the user unless you have asked 4B to perform these tasks.
- B. All installation and wiring must be in accordance with Local and National Electrical Codes and other standards applicable to your industry. (Please see the article “Hazard Monitoring Equipment Selection, Installation and Maintenance” at [www.go4b.com/usa](http://www.go4b.com/usa)). The installation of the wiring should be undertaken by an experienced and qualified professional electrician. Failure to correctly wire any product and/or machinery can result in the product or machine failing to operate as intended, and can defeat its design function.
- C. Periodic inspection by a qualified person will help assure your 4B product is performing properly. 4B recommends a documented inspection at least annually and more frequently under high use conditions.
- D. Please see the last page of this manual for all warranty information regarding this product.

### **CUSTOMER SAFETY RESPONSIBILITIES**

#### **1. READ ALL LITERATURE PROVIDED WITH YOUR PRODUCT**

Please read all user, instruction and safety manuals to ensure that you understand your product operation and are able to safely and effectively use this product. If the

equipment is used in a manner not specified in this manual, the protection provided by the equipment may be impaired.

## **2. YOU BEST UNDERSTAND YOUR NEEDS**

Every customer and operation is unique, and only you best know the specific needs and capabilities of your operation. Please call the 24-hour hotline at 309-698-5611 for assistance with any questions about the performance of products purchased from 4B. 4B is happy to discuss product performance with you at any time.

## **3. SELECT A QUALIFIED AND COMPETENT INSTALLER**

Correct installation of the product is important for safety and performance. If you have not asked 4B to perform the installation of the unit on your behalf, it is critical for the safety of your operation and those who may perform work on your operation that you select a qualified and competent electrical installer to undertake the installation. The product must be installed properly to perform its designed functions. The installer should be qualified, trained, and competent to perform the installation in accordance with Local and National Electrical Codes, all relevant OSHA Regulations, as well as any of your own standards and preventive maintenance requirements, and other product installation information supplied with the product. You should be prepared to provide the installer with all necessary installation information to assist in the installation.

## **4. ESTABLISH AND FOLLOW A REGULAR MAINTENANCE AND INSPECTION SCHEDULE FOR YOUR 4B PRODUCTS**

You should develop a proper maintenance and inspection program to confirm that your system is in good working order at all times. You will be in the best position to determine the appropriate frequency for inspection. Many different factors known to the user will assist you in deciding the frequency of inspection. These factors may include but are not limited to weather conditions; construction work at the facility; hours of operation; animal or insect infestation; and the real-world experience of knowing how your employees perform their jobs. The personnel or person you select to install, operate, maintain, inspect or perform any work whatsoever, should be trained and qualified to perform these important functions. Complete and accurate records of the maintenance and inspection process should be created and retained by you at all times.



## **5. RETAIN AND REFER TO THE OPERATION MANUAL FOR 4B'S SUGGESTED MAINTENANCE AND INSPECTION RECOMMENDATIONS**

As all operations are different, please understand that your specific operation may require additional adjustments in the maintenance and inspection process essential

to permit the monitoring device to perform its intended function. Retain the Operation Manual and other important maintenance and service documents provided by 4B and have them readily available for people servicing your 4B equipment. Should you have any questions, please call the 24-hour hotline number 309-698-5611, contact your local distributor, or use one of the contact ways available in our website [www.go4b.com/usa](http://www.go4b.com/usa).

## 6. SERVICE REQUEST

If you have questions or comments about the operation of your unit or require the unit to be serviced please call the 24-hour hotline number 309-698-5611, contact your local distributor, or use one of the ways available in our website [www.go4b.com/usa](http://www.go4b.com/usa). Please have available product part numbers, serial numbers, and approximate date of installation. In order to assist you, after the product has been placed into service, complete the online product registration section which is accessed via our website [www.go4b.com/usa](http://www.go4b.com/usa).

 <b>WARNING</b>	
 	<p>Moving parts can crush and cut.</p> <p>Lockout power before removing guard or servicing.</p> <p>Do NOT operate with guard removed.</p>

## PRODUCT OVERVIEW

The VIBMIL is a vibration sensor used to measure and monitor vibration levels of machinery or structures in industrial applications. The VIBMIL converts the mechanical motion into an electrical signal and delivers a 4-20mA analogue current output, which can be analysed, monitored and used by other controllers/PLCs or systems for various purposes.

The 4-20mA output represents the measurement from the vibration sensor. In this standardized signal range, 4mA corresponds to the lowest or zero vibration level (minimum measurement), while 20mA represents the highest vibration level (maximum measurement) that the sensor can detect.

The VIBMIL offers an integrated temperature sensor option for condition monitoring. Both the NTC and Pt100 temperature sensor versions are available with a 4-core cable.

Additionally, the VIBMIL features a 3/4" NPT conduit thread, allowing for fitting a cable conduit, which provides extra protection for the cable in applications where cables are at risk of environmental damage.

## PACKAGE CONTENT

1x VIBMIL Vibration Transmitter

1x Short Form Instruction Manual



1x 1/4"-28 UNF Set Screw

## SPECIFICATIONS

Operating Voltage Range	+15 VDC to +24 VDC (+10%)
Power Dissipation Max	0.56 Watts Max
Measuring Range	0 – 25 mm/s RMS Velocity, (VIBMILx1xVxx) – Standard 0 – 50 mm/s RMS Velocity, (VIBMILx2xVxx) - Optional
Frequency Range	10 Hz to 1kHz (VIBMILx1xVxx) – Standard 10 Hz to 400 Hz (VIBMILx2xVxx) – Optional
Output	4 – 20 mA proportional to Measuring Range
Maximum Load	@15VDC ≈150 Ohms, @24VDC ≈600 Ohms
Optional Temp Sensor	NTC (VIBMILxxNVxx) or Pt100 (VIBMILxxPVxx)
Power-on Time	< 10 sec
Operating Temperature	-40 °C to +50 °C
Dimensions	Height 72 mm x Width 27 mm
Mounting Threads	1/4"-28 UNF female thread

Housing Material	Stainless Steel
Cable	3 m (9.8 ft) long, 4 core 24 AWG
Weight	170g

## APPROVALS

	<p><b>VIBMIL....CAI...</b></p> <p>Class II Division 1 Groups E, F&amp;G T<sub>200</sub>90°C  AEx / Ex ta IIIC T<sub>200</sub>90°C Da IP66  -40°C ≤ Ta ≤ +50°C  MET Labs listing – E115704</p>
	<p><b>VIBMIL....CAI</b></p> <p>CML23ATEX3168X  Ex II 1D Ex ta IIIC T<sub>200</sub>90°C Da IP66  -40°C ≤ Ta ≤ +50°C</p>
	<p><b>VIBMIL....CAI</b></p> <p>CML23UKEX3169X  Ex II 1D Ex ta IIIC T<sub>200</sub>90°C Da IP66  -40°C ≤ Ta ≤ +50°C</p>
<p><b>IECEX</b></p>	<p><b>VIBMIL....CAI</b></p> <p>IECEX CML23.0057X  Ex ta IIIC T<sub>200</sub>90°C Da IP66  -40°C ≤ Ta ≤ +50°C</p>

## DIMENSIONS

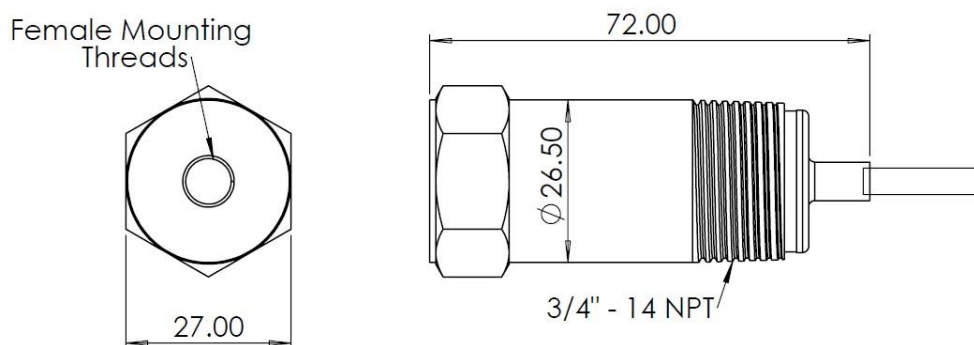

Dimensions in mm



## SPECIFIC CONDITIONS OF USE

1. The sensor shall be connected to a suitable external earth via the 3/4"-14 NPT male thread or via the machine on which the sensor is mounted using the female mounting thread.
2. The integral cable shall be terminated in a suitably certified enclosure or in a safe area.
3. The supply circuit of the system to which the equipment is connected shall be protected by a suitably rated fuse capable of interrupting a prospective short circuit current of 1.5 kA.

## STANDARD WIRING DIAGRAM

All wiring must be in accordance with local and national electrical codes (e.g. NEC, CEC, EN IEC 60079-14) and should be undertaken by an experienced and qualified electrician.

If required, mount a suitable junction box within the supplied length of the product's cable and (if required, using a suitable conduit to protect the cables) make the necessary wiring connections inside this junction box.

Always use dust/liquid tight flexible metal conduit with approved fittings to protect the sensor cables. Use rigid metal conduit to protect the cables from the sensors to the control unit. Conduit systems can channel water due to ingress and condensation directly to sensors and sensor connections which over time will adversely affect the performance of the system. As such, the installation of low point conduit drains is recommended for all sensors.

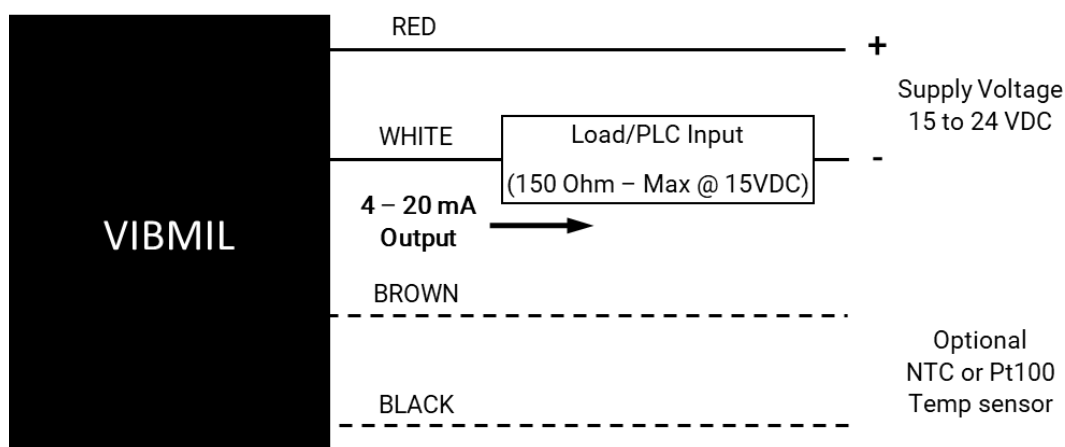

### NOTE

It is important to observe the correct Supply Polarity when wiring the sensor. The Red wire should always be connected to the power (+Ve) and White wire must be connected to the load to measure the current.

## INSTALLATION

All installations must conform to the local electrical wiring regulations (such as NEC, CEC, EN IEC 60079-14).

The VIBMIL is equipped with female 1/4"-28 UNF female mounting thread, allowing the use of a screw, stud, or mounting stud to secure the sensor to the desired application.

The sensor is supplied with a 1/4"-28 UNF set screw as standard. Optional converters to M8 and M6 male threads are available.

To achieve maximum sensitivity, mount the sensor vertically along the Y-axis of the machinery.

To ensure accurate readings and proper functioning of the VIBMIL, securely fix it to a level surface during installation.

When fastening the sensor to the machinery, as the cable is integrated into the sensor, make sure to rotate the cable alongside the sensor to prevent any wire damage caused by twisting.

## TESTING AND MAINTENANCE

Periodically test the Vibration Transmitter and the system to ensure that both are operating correctly.

1. Check that the unit is correctly installed. (See Electrical Setup)
2. Ensure that all cabling is in a good state, and that all the electrical connections are secure and in good order.

### **WARNING**

If the system does not immediately shutdown as expected or alarm as required, then remove the machine from service until the problem has been diagnosed and corrected.









## **1. EXCLUSIVE WRITTEN LIMITED WARRANTY**

All products sold are warranted by the company 4B Components Limited and 4B Braime Components Limited herein after referred to as 4B to the original purchaser against defects in workmanship or materials under normal use for one (1) year after date of purchase from 4B. Any product determined by 4B at its sole discretion to be defective in material or workmanship and returned to a 4B branch or authorized service location, as 4B designates, shipping costs prepaid, will be, as the exclusive remedy, repaired or replaced at 4B's option.

## **2. DISCLAIMER OF IMPLIED WARRANTY**

No warranty or affirmation of fact, expressed or implied, other than as set forth in the exclusive written limited warranty statement above is made or authorized by 4B. 4B specifically disclaims any liability for product defect claims that are due to product misuse, abuse or misapplications, as authorized by law, 4B specifically disclaims all warranties that the product is fit or merchantable for a particular purpose.

## **3. NO WARRANTY "BY SAMPLE OR EXAMPLE"**

Although 4B has used reasonable efforts to accurately illustrate and describe the products in its catalogs, literature, and websites, such illustrations and descriptions are for the sole purpose of product identification and do not express or imply a warranty affirmation of fact, of any kind or a warranty or affirmation of fact that the products will conform to their respective illustrations or descriptions. 4B expressly disclaims any warranty or affirmation of fact, expressed or implied, other than as set forth in the exclusive written limited warranty statement above, including, without limitation, the implied warranties of merchantability and fitness for a particular purpose.

## **4. LIMITATION OF DAMAGES**

Any liability for consequential, incidental, special, exemplary, or punitive damages, or for loss of profit, whether direct or indirect, is expressly disclaimed.

4B is the worldwide leading manufacturer of high-quality, technologically advanced material handling and electronic components.



## 4B Locations Around the World



### USA

4B Components Ltd.  
625 Erie Avenue  
Morton, IL 61550  
Tel: +1 (309) 698-5611

### France

4B France  
35 bis, rue du 8 mai 1945,  
Villers Bretonneux, F-80800  
Tel: +33 (0) 3 22 42 32 26

### Australia

4B Australia  
Building 1, 41 Bellrick St,  
Acacia Ridge 4110,  
Queensland  
Tel: +61 (0)7 3216 9365

### United Kingdom

4B Braime Components Ltd.  
Hunslet Road  
Leeds, LS10 1JZ  
Tel: +44 (0) 113 246 1800

### Germany

4B Deutschland  
35 bis, rue du 8 mai 1945,  
Villers Bretonneux, F-80800  
France  
Tel: +49 (0) 2333 601681

### China

4B China  
F1, Building 5A,  
8 West Lake Road Wujin High &  
New Technology Develop. Zone  
Changzhou 213164  
Jiangsu Province  
Tel: +86-136 0160 9266

### Thailand

4B Asia Pacific  
Build No.899/1 Moo 20  
Soi Chongsiri, Bangplee-Tam Ru Road  
Tanbon Bangpleeyai, Amphur Bangplee  
Samutprakarn 10540  
Tel: +66 (0) 2 173-4339

### South Africa

4B Africa  
14 Newport Business Park  
Mica Drive, Kya Sand  
2163 Johannesburg  
Tel: +27 (0) 11 708 6114

### United Arab Emirates

4B Braime Components Limited  
Sharjah International Airport Free Zone  
Saif Zone, Y Building, Office no. Y-44A  
P.O Box: SHJ-0., UAE reg. no. 23784  
Tel: +971 (0) 6 5212 044