



# **B400E MANUAL**

**BELT ALIGNMENT MONITOR**

**Model B4004V4CAI & B4004V46CAI**

**Important: This document should be read carefully before commencing  
installation**

**Rev 6 June 2013**

# CONTENTS

## APPROVALS

## INTRODUCTION

### 1 SPECIFICATIONS

- 1.1 CONTROL UNIT
- 1.2 BELT ALIGNMENT SENSOR

### 2 INSTALLATION INSTRUCTIONS

- 2.1 CONTROL UNIT
- 2.2 BELT ALIGNMENT SENSOR

### 3 ELECTRICAL WIRING

### 4 OPERATING INSTRUCTIONS

- 4.1 ADJUSTMENT OF ALIGNMENT SENSORS
- 4.2 ADJUSTMENT OF SWITCHES
- 4.3 THE TEST FUNCTION
- 4.4 STARTING
- 4.5 NORMAL RUNNING
- 4.6 NORMAL STOPPING
- 4.7 MISALIGNMENT ALARM
- 4.8 MISALIGNMENT STOP (SHUT DOWN)
- 4.9 RESTARTING
- 4.10 TWO SEPARATE BELTS
- 4.11 ONE BELT WITH FOUR SENSORS
- 4.12 Liability and Indemnity

### 5 FAULT FINDING

#### DRAWINGS

- A B400 Elite General arrangement drawing
- B&C Examples of sensor positioning
- D&E AC supply connection details for the B400 Elite
- F&G DC supply connection details for the B400 Elite
- H BS15V10A sensor wiring details
- I TouchSwitch sensor TS1V4CA and TS2V4CA wiring details
- J General Connection detail for a typical 3 wire capacitance sensor

Dear 4B Customer:

Congratulations on your purchase. 4B appreciates your business and is pleased you have chosen our products to meet your needs.

Please read in its entirety and understand the literature accompanying the product before you place the product into service. Please read the safety precautions carefully before operating the product. With each product you purchase from 4B, there are some basic but important safety considerations you must follow to be sure your purchase is permitted to perform its design function and operate properly and safely, giving you many years of reliable service. Please read and understand the Customer Safety Responsibilities listed below. Failure to follow this safety directive and the Operation Manuals and other material furnished or referenced, may result in serious injury or death.

#### ***SAFETY NOTICE TO OUR CUSTOMERS***

- A. In order to maximize efficiency and safety, selecting the right equipment for each operation is vital. The proper installation of the equipment, and regular maintenance and inspection is equally important in continuing the proper operation and safety of the product. The proper installation and maintenance of all our products is the responsibility of the user unless you have asked 4B to perform these tasks.
- B. All installation and wiring must be in accordance with Local and National Electrical Codes and other standards applicable to your industry. (Please see the article "Hazard Monitoring Equipment Selection, Installation and Maintenance" at [www.go4b.com](http://www.go4b.com).) The installation of the wiring should be undertaken by an experienced and qualified professional electrician. Failure to correctly wire any product and/or machinery can result in the product or machine failing to operate as intended, and can defeat its design function.
- C. Periodic inspection by a qualified person will help assure your 4B product is performing properly. 4B recommends a documented inspection at least annually and more frequently under high use conditions.
- D. Please see the last page of this manual for all warranty information regarding this product.

#### ***CUSTOMER SAFETY RESPONSIBILITIES***

##### **1. READ ALL LITERATURE PROVIDED WITH YOUR PRODUCT**

Please read all user, instruction and safety manuals to ensure that you understand your product operation and are able to safely and effectively use this product.

##### **2. YOU BEST UNDERSTAND YOUR NEEDS**

Every customer and operation is unique, and only you best know the specific needs and capabilities of your operation. Please call the 24-hour hotline at 309-698-5611 for assistance with any questions about the performance of products purchased from 4B. 4B is happy to discuss product performance with you at any time.

### **3. SELECT A QUALIFIED AND COMPETENT INSTALLER**

Correct installation of the product is important for safety and performance. If you have not asked 4B to perform the installation of the unit on your behalf, it is critical for the safety of your operation and those who may perform work on your operation that you select a qualified and competent electrical installer to undertake the installation. The product must be installed properly to perform its designed functions. The installer should be qualified, trained, and competent to perform the installation in accordance with Local and National Electrical Codes, all relevant OSHA Regulations, as well as any of your own standards and preventive maintenance requirements, and other product installation information supplied with the product. You should be prepared to provide the installer with all necessary installation information to assist in the installation.

### **4. ESTABLISH AND FOLLOW A REGULAR MAINTENANCE AND INSPECTION SCHEDULE FOR YOUR 4B PRODUCTS**

You should develop a proper maintenance and inspection program to confirm that your system is in good working order at all times. You will be in the best position to determine the appropriate frequency for inspection. Many different factors known to the user will assist you in deciding the frequency of inspection. These factors may include but are not limited to weather conditions; construction work at the facility; hours of operation; animal or insect infestation; and the real-world experience of knowing how your employees perform their jobs. The personnel or person you select to install, operate, maintain, inspect or perform any work whatsoever, should be trained and qualified to perform these important functions. Complete and accurate records of the maintenance and inspection process should be created and retained by you at all times.

### **5. RETAIN AND REFER TO THE OPERATION MANUAL FOR 4B'S SUGGESTED MAINTENANCE AND INSPECTION RECOMMENDATIONS**

As all operations are different, please understand that your specific operation may require additional adjustments in the maintenance and inspection process essential to permit the monitoring device to perform its intended function. Retain the Operation Manual and other important maintenance and service documents provided by 4B and have them readily available for people servicing your 4B equipment. Should you have any questions, please call the 4B location who supplied the product or the 24-hour hotline number in the USA -309-698-5611.

### **6. SERVICE REQUEST AND ONLINE PRODUCT REGISTRATION**

If you have questions or comments about the operation of your unit or require the unit to be serviced please contact the 4B location who supplied the product or send your request via fax (309-698-5615), email (4b-usa@go4b.com), or call us via our 24-hour hotline number in the USA - 309-698-5611. Please have available product part numbers, serial numbers, and approximate date of installation. In order to assist you, after the product has been placed into service, complete the Online Product Registration section which is accessed via our website [www.go4b.com](http://www.go4b.com)

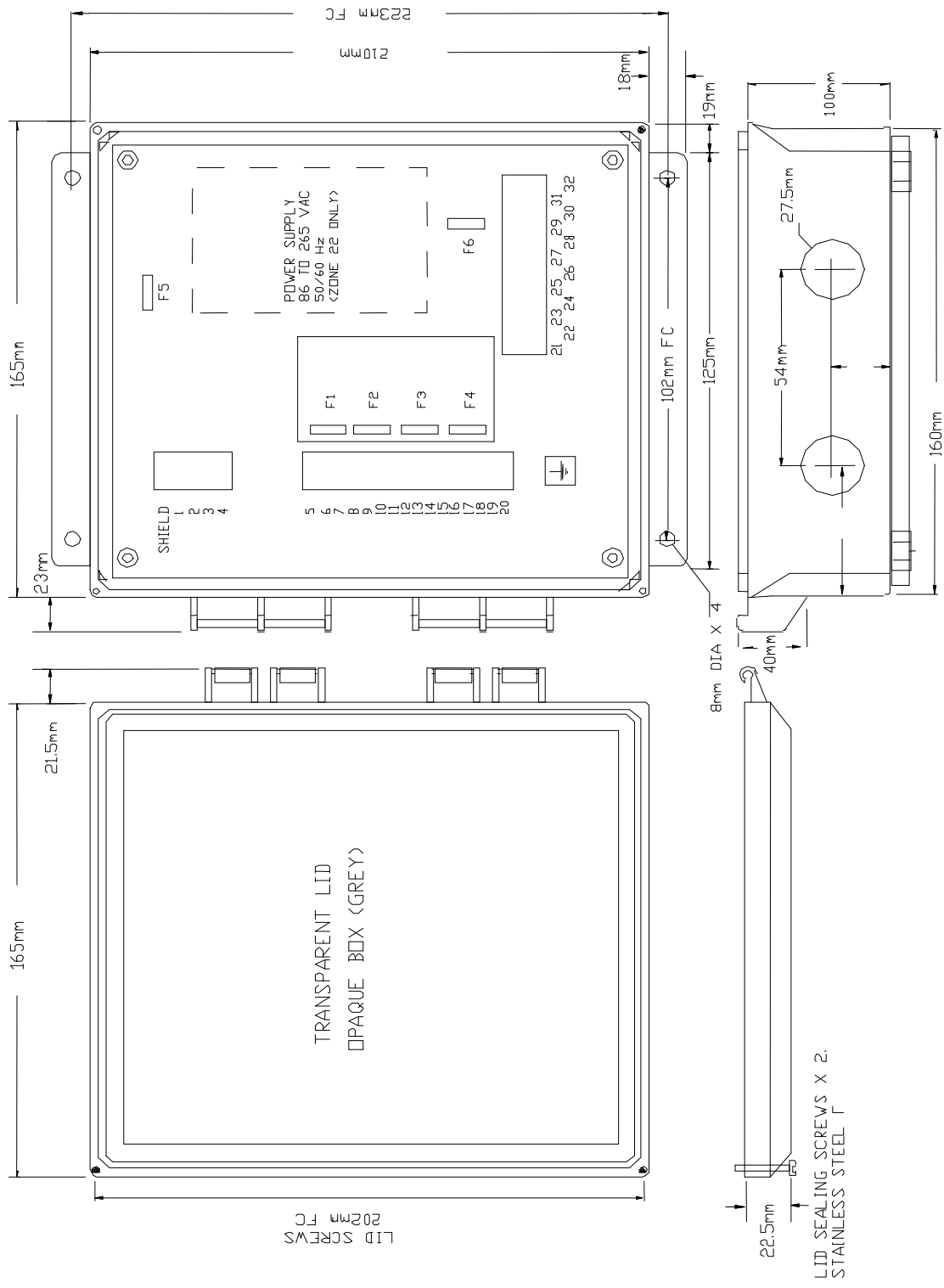

# Approvals

## Certification Markings:

Ex tb IIIC T125° Db IP66 T<sub>AMB</sub> -20°C to +50°C IECEX BAS05.0026X

CE 1180 Ex II 2D Ex tb IIIC T125° Db IP66 T<sub>AMB</sub> -20°C to +50°C Baseefa04ATEX0131X

Ex tc IIIC T125°Dc IP66 T<sub>AMB</sub> -20°C to +45°C IECEX BAS11.0018X

CE 1180 Ex II 3D Ex tc IIIC T125°Dc IP66 T<sub>AMB</sub> -20°C to +45°C Baseefa II ATEX 0033X



Ex tb IIIC T125°C Db IP66 Tamb -20°C to +50°C  
Zone 21 AEx tb IIIC T125°C Db IP66 Tamb -20°C to +50°C  
Class II Division 1, Groups E, F and G T125°C  
(When used with a Class2 power supply)



Ex tc IIIC T125°C Dc IP66 Tamb -20°C to +45°C  
Zone 22 AEx tc IIIC T125°C Dc IP66 Tamb -20°C to +45°C  
Class II Division 2, Groups F and G T125°C

Power dissipation in Watts  
ATEX category 2D : 12 Watts  
ATEX category 3D : 25 Watts

CSA Division 1 : 12 Watts  
CSA Division 2 : 12 Watts

## To Open the Lid:

1. Disconnect power (isolate ALL circuits)
2. Untighten the lid securing screws
3. Carefully open the lid ensuring that the gasket is not damaged and remains in place

## To Close the Lid:

1. Check that the gasket is correctly fitted into the box groove and is undamaged.
2. Tighten the lid screws.
3. Check that the lid and box are correctly mated.

**Note 1: Because of the manner in which the B400 works, the DC supply to the B400 will become the supply to the sensors. E.g. If the B400 is powered at 24 VDC then the sensors will be powered at 24 VDC.**

## Special conditions for safe use:

**WARNING: Static Hazard - Clean only with a damp cloth.**

# **B400 ELITE BELT ALIGNMENT MONITOR**

## **INTRODUCTION**

The B400 Elite is a microprocessor controlled unit which is able to accept signals of alignment from one or two belt conveyors and is able to cause alarm and shutdown of the conveyor and or feeders, when hazardous conditions are detected. The control unit is housed in a self contained wall-mounting enclosure, and the alignment sensors are separate items for mounting on the conveyor. The B400 Elite will operate from 100 to 240v AC  $\pm 10\%$  or from 24v DC depending upon the model chosen.

The belt alignment sensors operate in pairs to detect the correct alignment of belts used on conveyors, elevators and other similar equipment. The control unit can accept signals from pairs of sensors which may be on one or on two separate belts. When both pairs of sensors are mounted on one conveyor, they are intended to monitor each end of the belt. When both pairs of sensors are mounted on two different conveyors, they are intended to monitor the units independently.

## **1. SPECIFICATIONS**

### **1.1 The Control Unit**

A plastic enclosure houses the electronics and terminal connectors. The unit contains a printed circuit board to accommodate power supply circuitry, output relays, microprocessor and terminals. A short ribbon cable is connected to the lid of the enclosure where the indicator lamps are mounted. Adjustments are provided on the printed circuit board for setting up. A 'touch button' is mounted in the lid to allow the unit to be tested during operation.

Electrical Supply (B4004V46CAI)-	100 to 240 VAC $\pm 10\%$ 50/60Hz (Zone 22 only)
-	24 VDC $\pm 10\%$
Electrical Supply (B4004V4CAI)-	24 VDC $\pm 10\%$ (Zone 21)
Power Consumption	- 12 WATTS (Max)
Alarm Relay A Contacts	- 1 Pole normally open 8A@ 250VAC Non Inductive
Alarm Relay B Contacts	- 1 Pole normally open 8A@ 250VAC Non Inductive
Stop Relay A Contacts	- 1 Pole normally open 8A@ 250VAC Non Inductive
Stop Relay B Contacts	- 1 Pole normally open 8A@ 250VAC Non Inductive
Sensor Inputs	- 10 to 30 VDC (Or same as supply)
Sensor Supply	- See Note 1: Current 200 ma available per sensor
Terminals	- Power 2.5mm <sup>2</sup> 16 AWG max
	- Signals 2.5mm <sup>2</sup> 16 AWG max Plug In
Height	- 9.7", 246mm
Width	- 7.4", 188mm
Depth	- 4", 102mm
Fixing Centres	- 8.75" high x 4" wide, 223mm x 102mm
Cable Entry	- 2 Holes 1 1/8" DIA, 27.5mm, 3/4" CONDUIT

Weight	-	3lbs, 1.3Kg
Status Indicator Lamps	-	Viewed through front panel
	-	POWER
	-	SENSOR 1A
	-	SENSOR 2A
	-	MISALIGNMENT A
	-	SENSOR 1B
	-	SENSOR 2B
	-	MISALIGNMENT B
	-	ALARM
	-	STOP A
	-	STOP B

#### Internal adjustments

- Alarm Delay Low/High Sensor Inputs A
- Alarm Delay Low/High Sensor Inputs B
- Stop Delay Low/High Sensor Inputs A
- Stop Delay Low/High Sensor Inputs B
- Belt misalignment when signal Low/High A
- Belt misalignment when signal Low/High B

**Note 1: Because of the manner in which the B400 works, the DC supply to the B400 will become the supply to the sensors. E.g. If the B400 is powered at 24 VDC then the sensors will be powered at 24 VDC. If the model B4004V46CAI is powered at mains voltage then the sensors will be powered at 24 VDC.**

### 1.2 The Belt Alignment Sensors

The B400 Elite has been optimised to work with  
 TouchSwitch type TS1V4CA/TS2V4CA (24 VDC only)  
 Capacitance sensor BS15V10A (24 VDC 5 wire)  
 The above sensors are certified ATEX Ex II 1D

You may use any device which has a voltage free contact available such as a relay, a micro switch or other mechanically operated switch. The B400 inputs are rated at 30 VDC at 20ma maximum.

Other sensors may also be used but the application may vary from the examples given in this manual. Please contact your supplier if you wish to consider other alternative sensor types. The **maximum** power available to sensors is 200ma per sensor (see page 9)

## 2 INSTALLATION INSTRUCTIONS

**Warning: Always lock-out and tag-out the machine prior to installation and set-up.**

**Wiring: All Wiring Must Be In Accordance With Local and National Electrical Codes and Should Be Undertaken By an Experienced and Professional, Qualified Electrician.**



## 2.1 The Control Unit

The Control Unit box should be installed in a suitable control or starter switch room and mounted at an eye level position so that the warning lights can be readily seen. The box should have sufficient space to open the lid for wiring and adjustment. An audible alarm, sounder or visual indicator lamp can be installed in or outside of the control room.



**The Control Unit is susceptible to static voltage. Connection of a clean ground to terminal 31 is essential for optimum performance. Prior to this connection, static handling precautions should be taken.**

### **Enclosure Installation:**

- a. The IP66 rating of the enclosure must be maintained when used in Zone 20 and 21 dust environment. You must use the correct cable, glands and sealing arrangement and in accordance with the installation codes detailed in BS EN 60079 and EN 50281
- b. Where other certified components are used as part of the assembly or installation procedure, the user must take in to account any limitations which might be listed on the relevant certificates.
- c. The box is supplied with 2 x 27.5mm (1 $\frac{1}{8}$ "") pre drilled holes in the bottom face. Unused entry apertures must be sealed using component certified stopping plugs Hawke International type 375 or 387. The end user must install component or apparatus certified stopping plugs and cable glands in strict accordance with the manufacturer's instructions. In order to connect conduit to the control unit enclosure, use a Myers™ hub or other equivalent fitting that is rated and suitable for the environment. **Further holes must not be added to the enclosure as this will invalidate any warranty and the product certification.**
- d. All wiring must be carried out in accordance with relevant codes of practice and / or instructions (BS EN 600079-14, EN50281).
- e. The voltage and current and maximum power dissipation shown on the box label must not be exceeded.
- f. The wiring insulation must extend to within 1 mm of the metal face of the terminal.
- g. All leads must be insulated for the appropriate voltage.
- h. Not more than 1 single or multiple strand cable is to be connected to any terminal unless multiple conductors have previously been joined in a suitable manner (e.g. boot lace ferrule) such that they present a single connection point to the terminal.
- i. A parallel shaft screwdriver of the correct size should always be used when tightening terminals.

## 2.2 The Alignment Sensors

- Two alignment sensors are required to be mounted on each conveyor/elevator.  
**See page 6 for recommended types**

### 3 ELECTRICAL WIRING

Refer to Drawings D to J

Terminal 1 and 2 (A+ and B-) are used for the RS485 serial communications bus (HotBus). Care should be taken to ensure that the connections are observed. Incorrect connection can result in loss of communications between nodes.

**WARNING: under no circumstances must the power supply connection be allowed to come into contact with these terminals; to do so would result in the failure of the communications interface.**

Terminals 3 and 4 (+ and 0V) are used to provide a 24 DC supply to the HotBus network node when required. This supply can be disabled by switch SW2 and is protected by F5.

Terminal 5 is used to provide +24 VDC power to sensor 1A and is protected by F1

Terminal 6 is used as input signal for channel 1A

Terminal 7 is not connected

Terminal 8 is 0 VDC for sensor 1A

Terminal 9 is used to provide +24 VDC power to sensor 2A and is protected by F2

Terminal 10 is used as input signal for channel 2A

Terminal 11 is not connected

Terminal 12 is 0 VDC for sensor 2A

Terminal 13 is used to provide +24 VDC power to sensor 1B and is protected by F3

Terminal 14 is used as input signal for channel 1B

Terminal 15 is not connected

Terminal 16 is 0 VDC for sensor 1B

Terminal 17 is used to provide +24 VDC power to sensor 2B and is protected by F4

Terminal 18 is used as input signal for channel 2B

Terminal 19 is not connected

Terminal 20 is 0 VDC for sensor 2B

Terminals 21 and 22 are volt free Alarm contacts for Alarm relay B rated 250 VAC @ 8 Amp non inductive.

Terminals 23 and 24 are volt free Alarm contacts for Alarm relay A rated 250 VAC @ 8 Amp non inductive.

Terminals 25 and 26 are volt free Stop contacts for Stop relay B rated 250 VAC @ 8 Amp non inductive.

Terminals 27 and 28 are volt free Stop contacts for Stop relay A rated 250 VAC @ 8 Amp non inductive.

Terminals 29 and 30 are for the AC power supply. This is only fitted when the B4004V46CAI is to be used in a Zone 22 application. The AC supply can be between 100 and 240 Volts  $\pm$  10% 50/60 HZ.

Terminal 31 is used for a ground (earth) -ve terminal when using a mains power supply or a 0 VDC terminal when using a separate DC power supply.

Terminal 32 is used for a positive +ve terminal when powering the B400 from a separate 24 VDC power supply.

### **Fuses:**

**It is very important to observe the fuse ratings used on the B400 elite.** The following fuse ratings **MUST** apply. See page 3 for the position of the fuses. Fuses 1 to 4 are located on the underside of the plug in circuit board to provide mechanical protection.

F1 to F5 must have a maximum rating of 100ma when used in a CAT 1D (Zone 20) installation.

F1 to F5 must have a maximum rating of 200ma when used in a CAT 2D (Zone 21) installation.

F1 to F5 has a recommended maximum rating of 200ma when used in a CAT 3D (Zone 22) installation.

F1 to F4 are used to limit the current available to each of the 4 sensors.

F5 is used to limit the current available to the internal electronics and terminals 3 and 4.

F6 is used to protect the AC power supply and should have a 1 Amp rating. This fuse is only required when used in Zone 22 installations.

In order to maintain the product certification, these fuses **MUST** be replaced with equivalent fuses at the same rating. Failure to do so will invalidate the certification and any warranties which may exist.

## **4 OPERATING INSTRUCTIONS**

### **4.1 Adjustment of Alignment Sensors**

Note: If the control unit is mounted in a hazardous area, switch the electrical supply **OFF before** opening the lid of the control unit to make the following adjustments. Close the lid **before** switching the electrical supply **ON**. Repeat this each time an adjustment is required inside the control unit.

Ensure that the Alignment Sensors have been correctly mounted as described in paragraph. 2.2. At this point it will be necessary to start the belt. Note that until the sensors are correctly set up and adjusted, the belt may not run continuously subject to the method of wiring to the motor starter. With the belt running and correctly aligned, adjust the sensitivity control potentiometers on each sensor in order to ensure a stable signal that is not affected by things such as vibration or loose material. When all sensor adjustments are complete, test the complete assembly to ensure that both sensors operate as expected.

## 4.2 Adjustment of Switches

**When used in a Zone 21 installation, ensure that the electrical supply to the control unit is OFF before opening the control unit lid.**

Open the lid of the control unit and locate 8 small slide switches, near the left hand row of terminals. Initially all 8 switches should be in the left position.

SWITCH 1 (Top) sets the delay between detecting a misalignment condition for sensors 1A and 2A, and energising ALARM RELAY 'A'. Left = 5secs, Right = 30secs

SWITCH 2 Sets the delay between detecting a misalignment condition for sensors 1B and 2B, and energising ALARM RELAY 'B'. Left = 5secs, Right = 30secs

SWITCH 3 Sets the delay between energising ALARM RELAY 'A' and de-energising STOP RELAY 'A'. Left = 30secs, Right = 60secs.

SWITCH 4 Sets the delay between energising ALARM RELAY 'B' and de-energising STOP RELAY 'B'. Left = 30secs, Right = 60secs.

SWITCH 5 Sets the normal operating level for the sensors 1A and 2A. Set to the left (HIGH) position expects the signal from the sensor to be normally high and to go low when a misalignment is detected. Set to the right (LOW) position expects the signal from the sensor to be normally low and to go high when a misalignment is detected.

SWITCH 6 Sets the normal operating level for the sensors 1B and 2B. Set to the left (HIGH) position expects the signal from the sensor to be normally high and to go low when a misalignment is detected. Set to the right (LOW) position expects the signal from the sensor to be normally low and to go high when a misalignment is detected.

It is recommended that the B400 should be used with switch 5 and 6 set to the high position and with the appropriate sensor connections as this provides 'fail safe' detection. In this mode, should the wiring become cut or if a sensor was to fail, then the B400 would see this as a misalignment and stop the conveyor/elevator which is a safe position in which to fail.

SWITCH 7 & 8 are not used.

## 4.3 The TEST function

### 4.3.1 Normal Test

The B400 Elite is equipped with a self test function, initiated by the test button on the lid of the control unit. When the button is pressed the Alarm lamp flashes and then the following automatic test is initiated as the button is released.

1. All lamps illuminate – the ALARM lamp continues to flash
2. After 5 seconds all lamps return to their normal conditions

This test can be performed when the elevator is running or stopped and tests the correct function of the microprocessor and of all lamps.

#### 4.3.2 Extended Test

If the Normal Test is initiated as in 4.3.1 and if the test button is pressed again, while the ALARM lamp is flashing, the extended test operates as follows:

1. All lamps illuminate – the ALARM lamp continues to flash
2. Pressing the test sensor again
3. The ALARM and STOP A lamps flash for a further 5 seconds (8 seconds total time)
4. The ALARM RELAY and STOP RELAYS are inverted and the ALARM, STOP A and STOP B lamps flash
5. After 3 seconds all lamps and relays return to their normal conditions

If this test is performed when the elevator is not running, the Alarm will sound but the STOP RELAYS will have no effect on the conveyor/elevator. If this test is performed when the conveyor/elevator is running, the Alarm will sound and the STOP RELAYS will stop the conveyor. If this test is performed when the B400 has stopped a conveyor, the relevant stop relay will re-energise during the test. This test should be performed on a regular basis to check the safety of the installation.

#### 4.4 Power up state

The B400 Elite conducts a self test at power up. After the self test is complete stop relays A and B will both energise, allowing the conveyor(s) to be started. If a belt or sensor is misaligned at this point, then the misalignment cycle will begin. On completion of the cycle, the stop relay associated with the sensor will de-energise and not allow starting of the conveyor or it will stop the conveyor if already started.

#### 4.5 Normal Running

As long as the relevant sensors both detect correctly, the belt is considered to be running normally and the relevant STOP relay will remain energised and the STOP indicator lamps will remain off.

#### 4.6 Normal Stopping

The conveyor may be stopped at any time in the usual manner. The B400 will not interfere with this process unless you have wired the stop relays in series with the conveyor motor contactor circuits and a belt misalignment has been detected.

#### 4.7 Misalignment Alarm

If one of the sensors detects a belt misalignment and this misalignment persists for more than 2 seconds, the amber belt misalignment led will illuminate. After a 10 or 20 seconds (set by either switch 1 or switch 2) the red alarm led will be illuminated and the relevant

alarm relay will energise. If the belt becomes realigned again during this period, the misalignment led, alarm led and alarm relay will automatically be reset.

#### 4.8 Misalignment Stop (Shutdown)

If the alarm relay remains energised for a time which is longer than 30 or 60 seconds (set on switch 3 or 4), the relevant STOP RELAY will de-energise and the relevant STOP lamp will energise. If the B400 is wired to operate with two independent conveyers, then only the conveyor with the misaligned belt will be stopped.

#### 4.9 Restarting

If the conveyor has been stopped due to a belt misalignment alarm, you must first correct the belt misalignment before attempting to restart the conveyor. Failure to correct the problem will result in the B400 preventing the restart of the conveyor because the stop relay will be de-energised.

#### 4.10 Two Separate Conveyors

If the A1+A2 and B1+B2 sensors are fitted to two separate conveyors, the above descriptions 4.1 to 4.9 apply separately to each belt and separate ALARM and STOP relays can be used.

#### 4.11 One Conveyor with Four Sensors

If the A1+A2 and B1+B2 sensors are mounted on the same conveyor/elevator, (for example A1+A2 at the far end and B1+B2 at the near end) the control unit will differentiate between misalignment faults at the two sensor locations. Normally, the two STOP relays would be connected so that either/both can stop the conveyor and either/both alarm relay will operate the alarm indicator.

#### 4.12 Liability and Indemnity:

- 1) **In respect of installation or applications of the goods as parts or components of other goods or machinery the buyer shall be solely responsible for the compliance and the installation with safety regulations issued by competent authorities and in force at the place of operation and/or for its compliance with any terms of insurance notified by the Buyer's insurance for personal injury or damage to property or loss of profit though fire, explosion, gas, or otherwise.**
- 2) **Neither the company nor its suppliers shall in any circumstances whatsoever be liable for any loss or damage suffered by the Buyer or by any third party howsoever caused involving any person, property, or interest, suffered by the Buyer or any third party directly or indirectly in connection with the use, functioning or state of the goods, unless the same shall arise out of the Company's negligence.**

- 3) The buyer shall indemnify the Company against all actions, claims, or demands by third parties, whether in tort or otherwise, howsoever arising, directly or indirectly, in connection with the use, functioning or state of the goods or in connection with the performance of service.**

#### Limitation of Liability

**Without prejudice to the foregoing, the Company shall in no circumstances be liable:**

- 1) For any incidental or consequential loss or damage suffer by the buyer, including without limitation, delay, detention, loss of production, loss of profit, or liability to third parties except liability for personal injury or death arising out of negligence by the Company.**
- 2) For any loss or damage covered by the insurance or which would ordinarily be covered by the insurance.**

#### Warranty

**The equipment is covered by 12 months warranty from the date of dispatch. Any faults arising due to faulty materials or workmanship in the original equipment within the warranty period will be corrected free of charge providing the equipment is returned to us freight paid.**



**go4b.com**

**Contact Information.**



## **CHECKLIST**

### **For problems after initial start-up**

1. Is there excessive interference on the electrical power supply? Power conditioners and surge (spike) suppressor may have to be fitted.
2. Has the wiring for the Sensors been routed away from power cables? See paragraph 2.2.
3. Are the Sensors mounted away from plastic abrasion liners (which could cause static interference), electric motors and other magnetic fields?
4. Is the B400 Elite circuit properly grounded?
5. Is the conveyor/elevator grounded to prevent static build-up?
6. Is the belt running true?
7. Does the belt stay in alignment when material is fed onto it?
8. Is the conveyor/elevator belt tightened up sufficiently to prevent belt slip and misalignment?
9. Have the Sensors been mounted rigidly and free from vibration?
10. Check that the Sensors do not foul the equipment.
11. Is the Micro-processor control unit overheating, if so mount in a temperature-controlled environment of maximum temperature 104°F (40°C).
12. Check that high powered 'Walkie Talkie' radios are not operated immediately near the B400 Elite control unit or Sensors as this will affect the performance.
13. If your conveyor/elevator has a weighted take up please ensure that there is sufficient weight on it to prevent belt slip.

## 5 FAULT FINDING CHART

SYMPTOM	CAUSE	REMEDIAL ACTION
LED on Alignment Sensor flashes	The sensitivity is incorrectly adjusted. Wiring connection faulty	Adjust the sensitivity until the signal is stable Check wiring
LED on Alignment Sensor does not change state	Sensor adjustment incorrect Interference in wiring	Sensitivity adjustment to high Use shielded cable and rigid conduit
Sensor LED on Control unit does not change when the belt is misaligned	Sensor position wrong Sensor not operating Wiring Fault Sensor connected to wrong terminals	See section 1 above Check wiring
Wrong Sensor LED on unit lights	Sensor connected to wrong input	See drawings H to J
Alarm LED on	Belt misaligned	Check belt
Stop LED on	Stop condition occurred Belt misaligned	Check belt Check sensors
Belt fails to start	Belt alignment incorrect Sensor alignment incorrect Wiring fault	Check belt Check sensor alignment Check wiring
Belt starts but fails to keep running	Belt alignment incorrect Sensor alignment incorrect Wiring fault	Check belt Check sensor alignment See drawings H to J

## Drawing 'A'

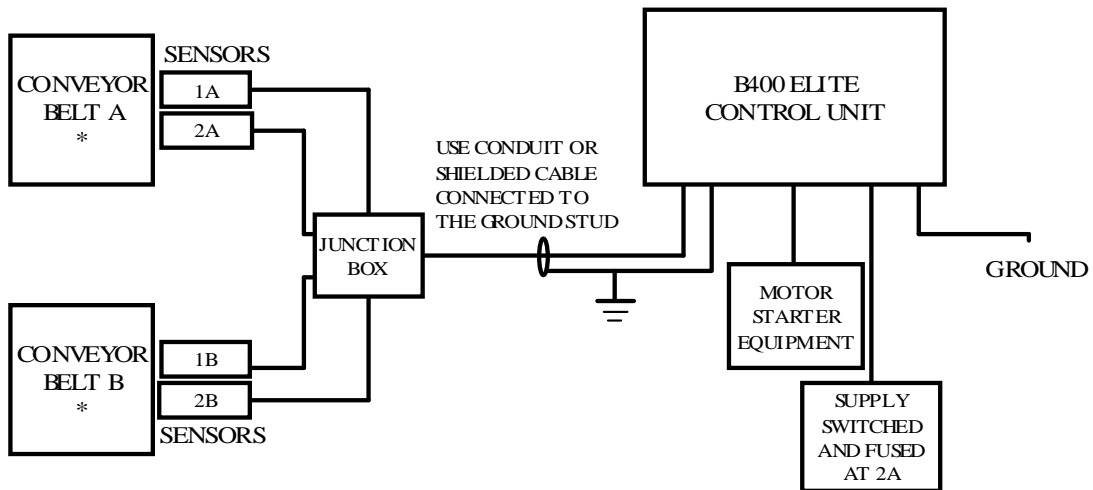

\* OR FAR AND NEAR END OF ONE CONVEYOR BELT

This drawing represents a general arrangement for the components used in a typical B400 installation. The following pages give more details about the mechanical and electrical requirements of the B400 and the sensors available for use with it.

# Examples of sensor positioning for belt misalignment detection.

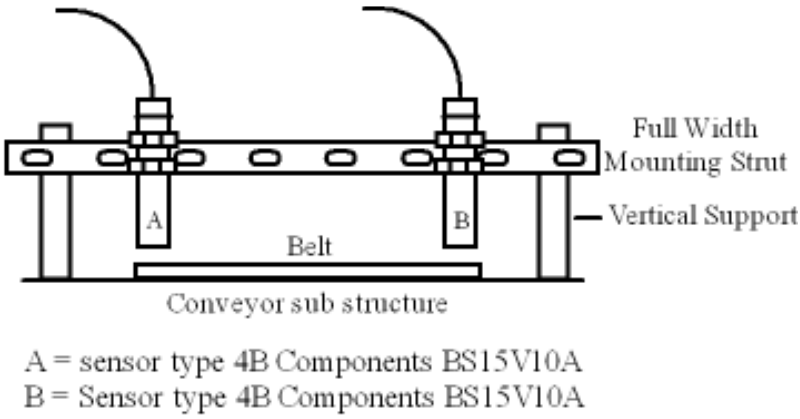

↔  
This method detects belt misalignment in either direction.

## Drawing 'B'

**When using the BS15V10A sensor in this way it is recommended that you set switch 5 and/or 6 to the left (high) position in order to provide failsafe operation.**

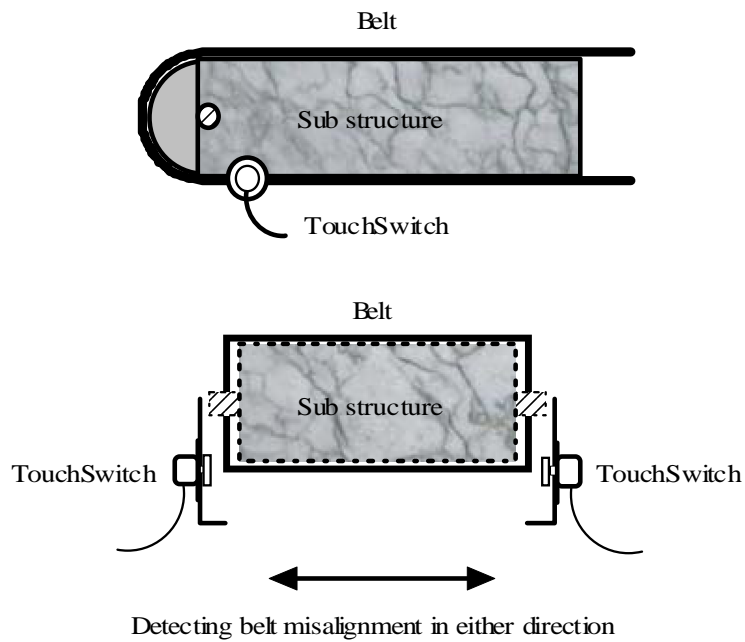

This example represents one method of locating the TouchSwitch sensors for detecting belt alignment. The exact number of sensors and their location is dependant upon the application.

## Drawing 'C'

Refer to the wiring section (Drawings H to J) for connections details for the different sensors.

AC Supply connection details for the B400 Elite

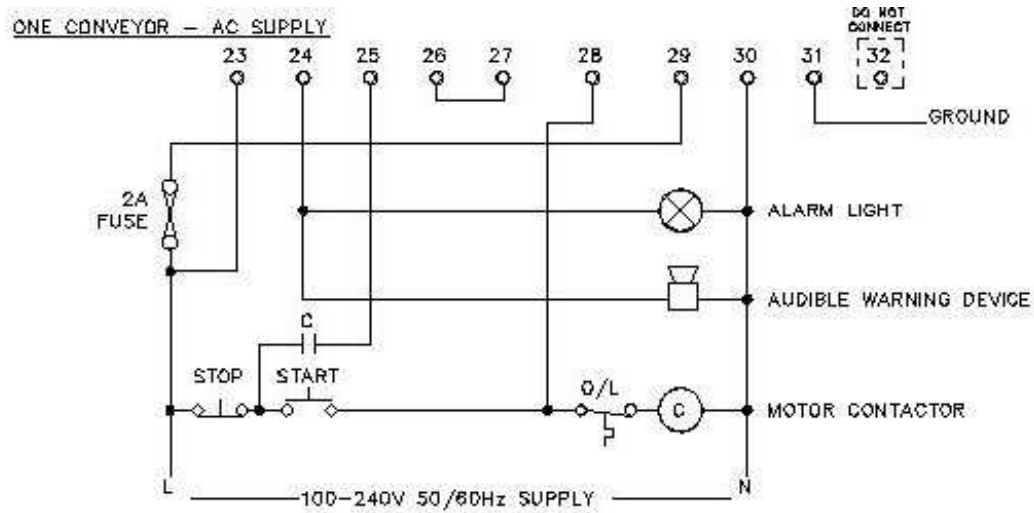

Drawing 'D'

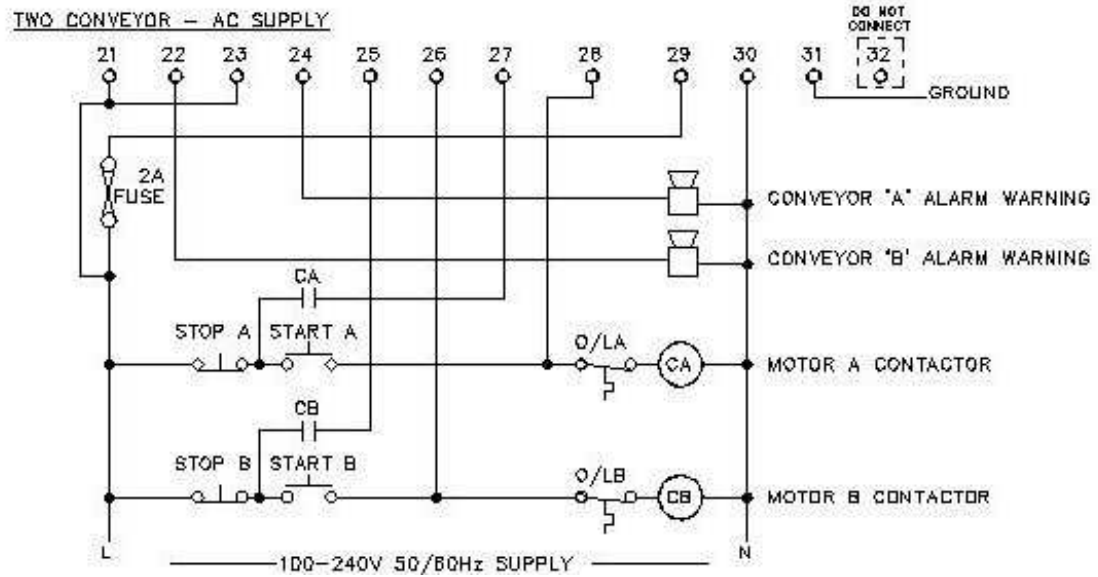

Drawing 'E'

## DC Supply connection details for the B400 Elite

ONE CONVEYOR - DC SUPPLY

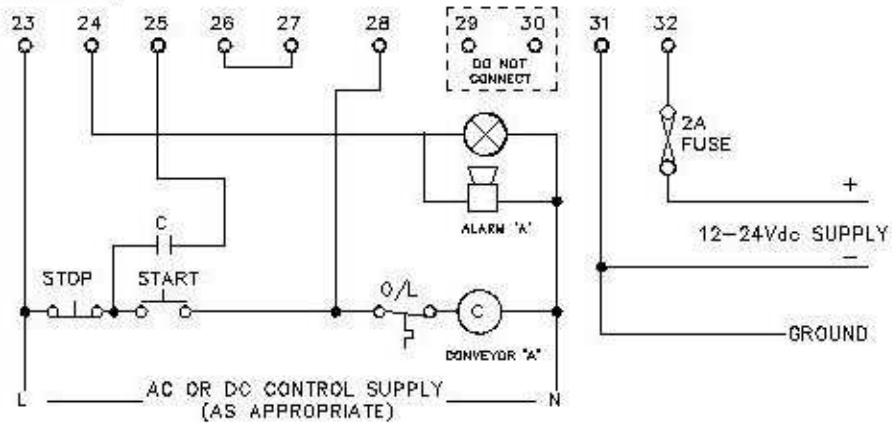

Drawing 'F'

TWO CONVEYOR - DC SUPPLY

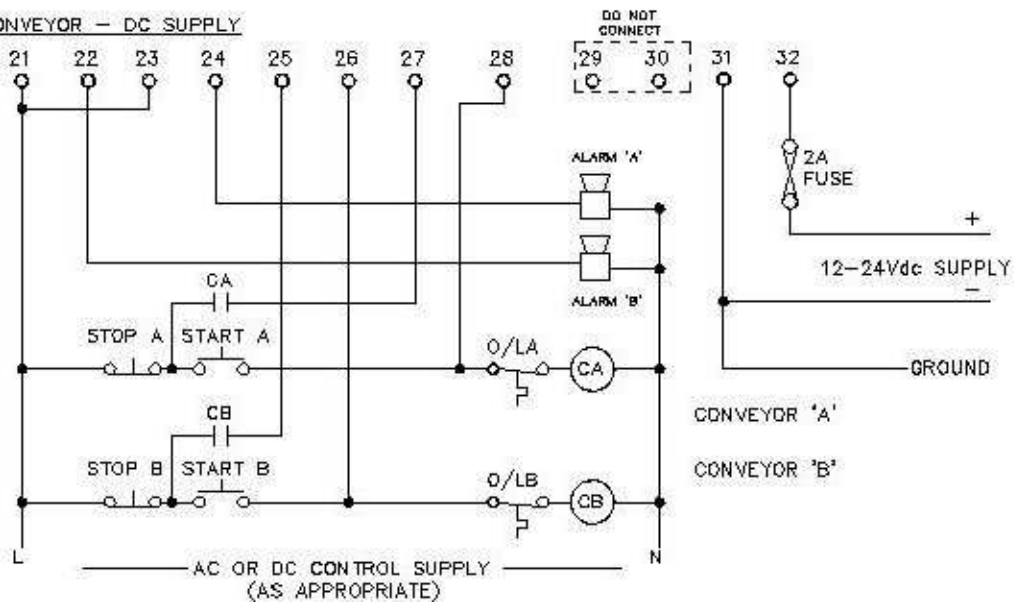

Drawing 'G'

## ALTERNATIVE SENSOR TYPES USED WITH THE B400 ELITE BELT ALIGNMENT MONITOR

### CONNECTION DETAILS FOR THE BS15V10A SENSOR CONNECTED TO THE B400 ELITE

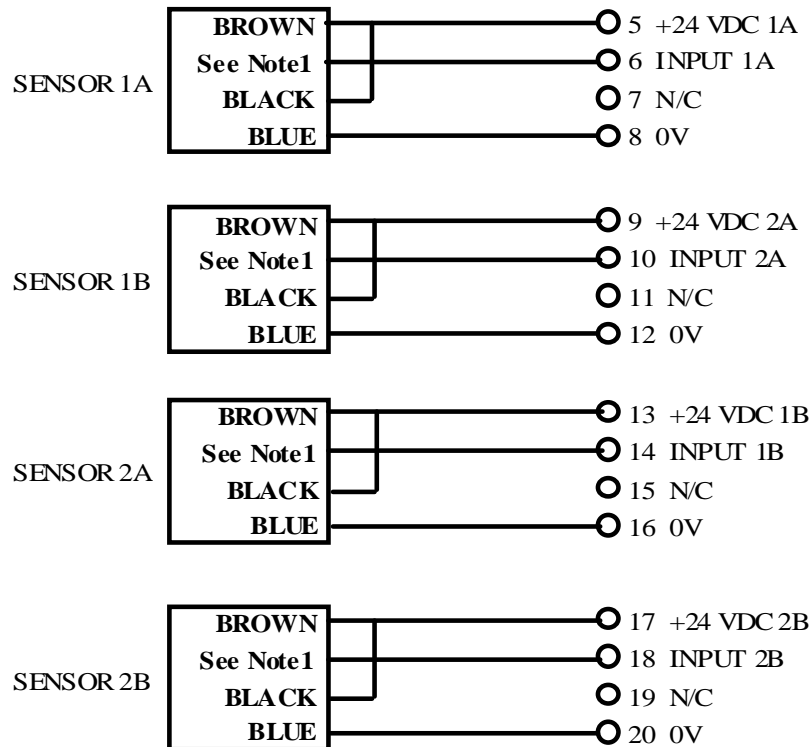

**NOTE 1: WIRE BLACK/ORANGE OR BLACK/RED MAY BE USED TO CONNECT THE SENSOR TO THE B400. THE CHOICE IS DEPENDANT UPON WHICH RELAY CONTACT YOU INTEND TO USE.**

Ensure that the unused wire is properly insulated against unintended connection.

**When using the BS15V10A sensor in this way it is recommended that you set switch 5 and/or 6 to the left (high) position in order to provide failsafe operation.**

Drawing 'H'



**ALTERNATIVE SENSOR TYPES USED WITH THE B400 ELITE BELT ALIGNMENT MONITOR**

**CONNECTION DETAILS FOR THE TS1V4CA AND TS2V4CA SENSOR  
CONNECTED TO THE B400 ELITE**

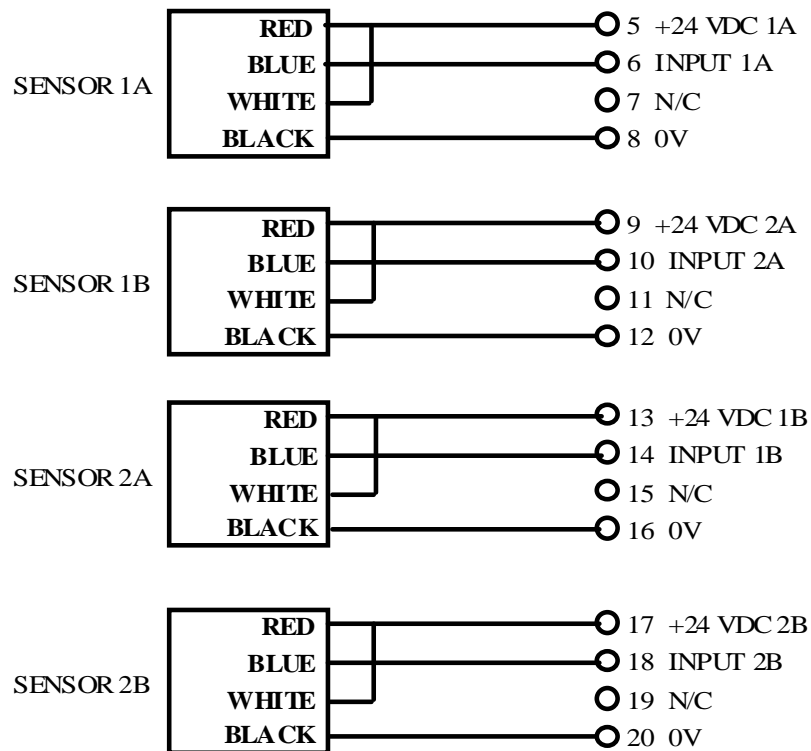

**NOTE 1: THE ORANGE WIRE IS NOT NORMALLY USED  
AND IS THE N/C CONTACT FROM THE RELAY.  
MAKE THIS WIRE SAFE SO AS NOT TO CAUSE ANY  
SHORT CIRCUITS. THE GREEN WIRE ON EACH  
TOUCHSWITCH SHOULD BE CONNECTED TO GROUND.  
REFER TO THE TOUCHSWITCH MANUAL FOR FURTHER DETAIL**

**When using the TouchSwitch in this way it is recommended that  
you set switch 5 and/or 6 to the left (high) position in order to provide  
failsafe operation.**

Drawing 'I'

**ALTERNATIVE SENSOR TYPES USED WITH THE B400 ELITE BELT ALIGNMENT MONITOR**

GENERAL CONNECTION DETAILS FOR THREE WIRE CAPACITOR  
SENSORS CONNECTED TO THE B400 ELITE

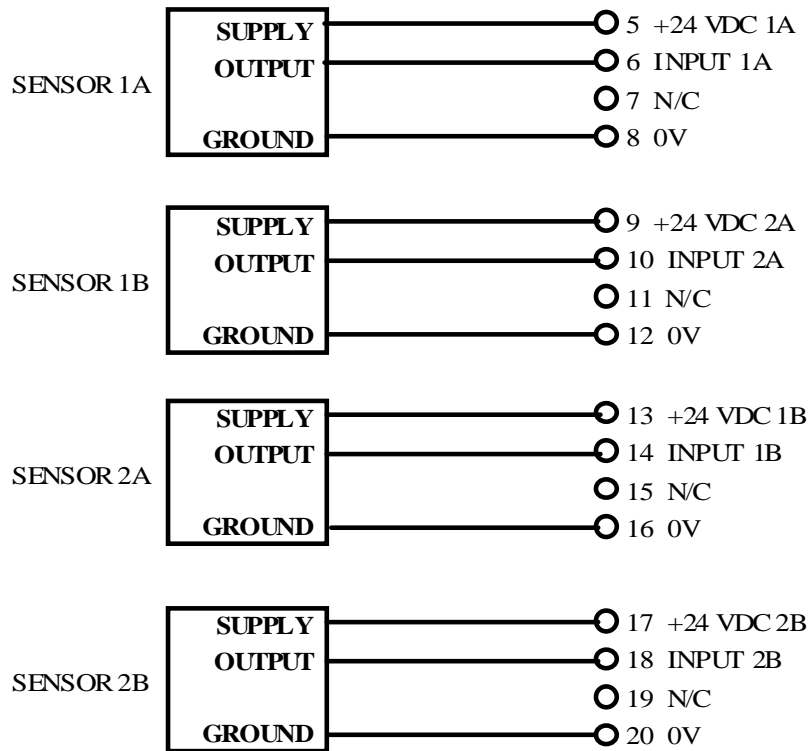

**NOTE 1: THE WIRING COLOURS USED WILL BE DETERMINED BY THE SENSOR USED. PLEASE REFER TO THE SENSOR MANUAL FOR DETAILS. THE B400 WILL WORK WITH NPN OR PNP OUTPUT TYPES DEPENDANT UPON THE SETTING OF SWITCH 5 AND 6 OF THE B400. WE RECOMMEND USING A TYPE THAT ALLOWS FOR FAIL SAFE OPERATION.**

Drawing 'J'

Document Revision	Date revised	Revisions made
R2	Oct 2010	Updated legal information, modified DoC
R3	-	-
R4	May 2011	Updated for new approvals
R5	Nov 2011	Updated Specification
R6	June 2013	Updated Certification