

INSTRUCTION MANUAL

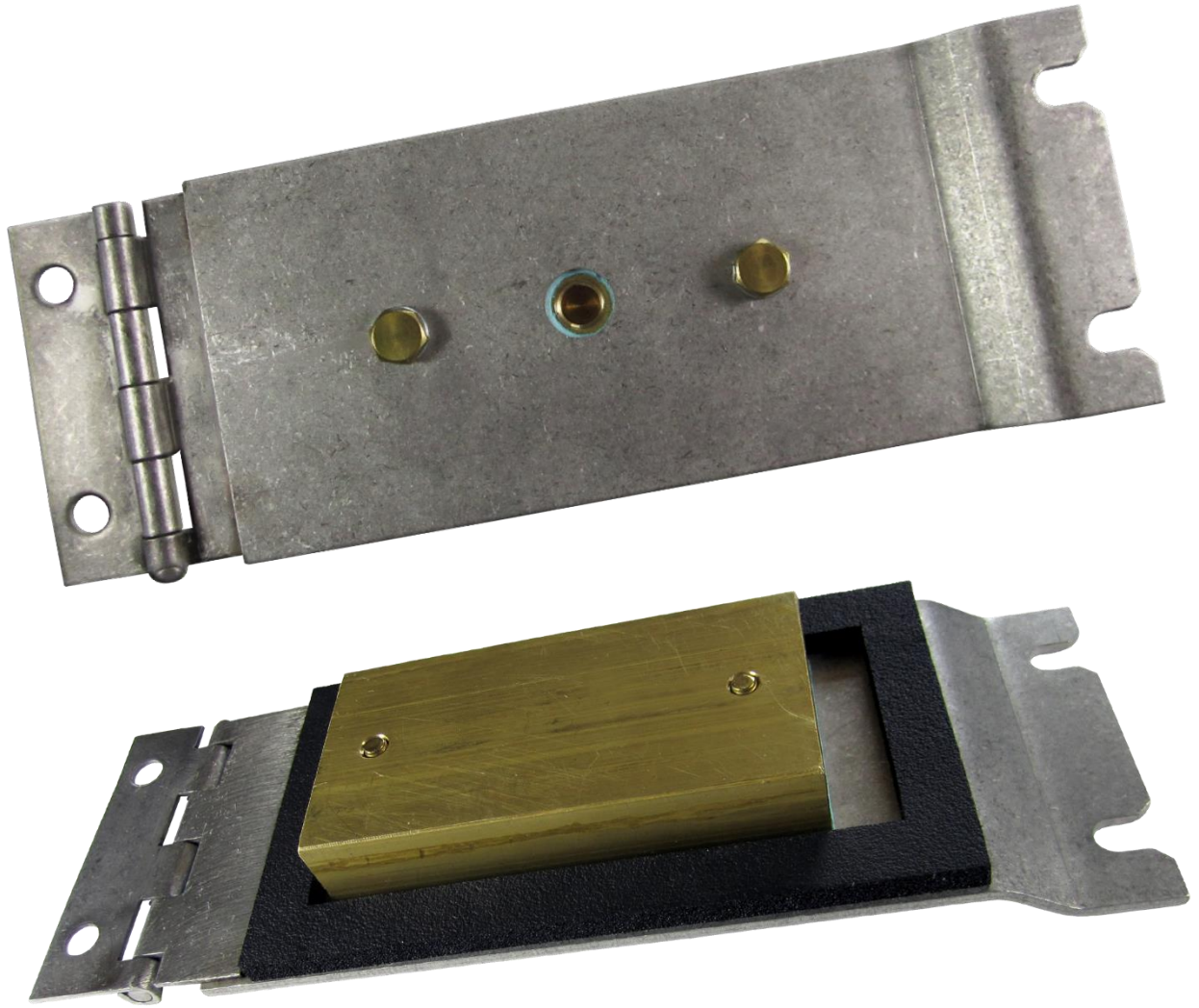



Rub Block Kit

Rub block, Inspection Door, Gasket, Shim, Bolts and Washers.

Part Number: RB2W4LR2

Rub Block, INSPECTION DOOR, RECTANGULAR 2" w X 4" l, USE WITH 1.8" NPT temperature sensor ADB2 series

 **WARNING**

Moving parts can crush and cut.

Lockout power before removing guard or servicing.

Do NOT operate with guard removed

 **DANGER**

Exposed buckets and moving parts will cause severe injury or death.

Lockout power before removing cover or inspection door.

TABLE OF CONTENTS

CUSTOMER SAFETY RESPONSIBILITIES	16
PRODUCT OVERVIEW.....	6
SENSOR SPECIFICATIONS.....	6
4-20 mA Sensors - ADBMIL1V4C/D2	7
NTC Sensors - ADB20V3CAI/D2	7
PT100 / RTD Sensors - ADB29V3CAI/D2	7
DIMENSIONS	8
INSTALLATION	9
SENSOR WIRING AND DIAGRAMS	11
SENSOR TESTING AND COMMISIONING.....	12
PRODUCT WARRANTY.....	15



- EN** To download the digital version of this instruction manual and to check other available languages scan the following QR code.
- ES** Para descargar la versión digital de este manual de instrucciones y consultar otros idiomas disponibles, escanee el siguiente código QR.
- PT** Para baixar a versão digital deste manual de instruções e verificar outros idiomas disponíveis, escaneie o seguinte código QR.
- FR** Pour télécharger la version numérique de ce manuel d'instructions et pour vérifier les autres langues disponibles, scannez le code QR suivant.
- DE** Um die digitale Version dieser Bedienungsanleitung herunterzuladen und andere verfügbare Sprachen zu überprüfen, scannen Sie den folgenden QR-Code.
- RU** Чтобы загрузить цифровую версию данного руководства по эксплуатации и проверить другие доступные языки, отсканируйте следующий QR-код.
- ZH** 要下載本說明手冊的數字版本並查看其他可用語言，請掃描以下二維碼。



CUSTOMER SAFETY RESPONSIBILITIES

4B appreciates your business and is pleased you have chosen our products to meet your needs.

Please read in its entirety and understand the literature accompanying the product before you place the product into service. Please read the safety precautions carefully before operating the product. With each product you purchase from 4B, there are some basic but important safety considerations you must follow to be sure your purchase is permitted to perform its design function and operate properly and safely, giving you many years of reliable service. Please read and understand the Customer Safety Responsibilities listed below. Failure to follow this safety directive and the Operation Manuals and other material furnished or referenced, may result in serious injury or death.

SAFETY NOTICE TO OUR CUSTOMERS

- A. In order to maximize efficiency and safety, selecting the right equipment for each operation is vital. The proper installation of the equipment, and regular maintenance and inspection is equally important in continuing the proper operation and safety of the product. The proper installation and maintenance of all our products is the responsibility of the user unless you have asked 4B to perform these tasks.
- B. All installation and wiring must be in accordance with Local and National Electrical Codes and other standards applicable to your industry. (Please see the article “Hazard Monitoring Equipment Selection, Installation and Maintenance” at www.go4b.com) The installation of the wiring should be undertaken by an experienced and qualified professional electrician. Failure to correctly wire any product and/or machinery can result in the product or machine failing to operate as intended and can defeat its design function.
- C. Periodic inspection by a qualified person will help assure your 4B product is performing properly. 4B recommends a documented inspection at least annually and more frequently under high use conditions.
- D. Please see the last page of this manual for all warranty information regarding this product.

CUSTOMER SAFETY RESPONSIBILITIES

1. READ ALL LITERATURE PROVIDED WITH YOUR PRODUCT

Please read all user, instruction and safety manuals to ensure that you understand your product operation and are able to safely and effectively use this product. If the equipment is used in a manner not specified in this manual, the protection provided by the equipment may be impaired.

2. YOU BEST UNDERSTAND YOUR NEEDS

Every customer and operation is unique, and only you best know the specific needs and capabilities of your operation. Please call the 24-hour hotline at 309-698-5611 for assistance with any questions about the performance of products purchased from 4B. 4B is happy to discuss product performance with you at any time.

3. SELECT A QUALIFIED AND COMPETENT INSTALLER

Correct installation of the product is important for safety and performance. If you have not asked 4B to perform the installation of the unit on your behalf, it is critical for the safety of your operation and those who may perform work on your operation that you select a qualified and competent electrical installer to undertake the installation. The product must be installed properly to perform its designed functions. The installer should be qualified, trained, and competent to perform the installation in accordance with Local and National Electrical Codes, all relevant OSHA Regulations, as well as any of your own standards and preventive maintenance requirements, and other product installation information supplied with the product. You should be prepared to provide the installer with all necessary installation information to assist in the installation.

4. ESTABLISH AND FOLLOW A REGULAR MAINTENANCE AND INSPECTION SCHEDULE FOR YOUR 4B PRODUCTS

You should develop a proper maintenance and inspection program to confirm that your system is in good working order at all times. You will be in the best position to determine the appropriate frequency for inspection. Many different factors known to the user will assist you in deciding the frequency of inspection. These factors may include but are not limited to weather conditions; construction work at the facility; hours of operation; animal or insect infestation; and the real-world experience of knowing how your employees perform their jobs. The personnel or person you select to install, operate, maintain, inspect or perform any work whatsoever, should be trained and qualified to perform these important functions. Complete and accurate records of the maintenance and inspection process should be created and retained by you at all times.

5. RETAIN AND REFER TO THE OPERATION MANUAL FOR 4B'S SUGGESTED MAINTENANCE AND INSPECTION RECOMMENDATIONS

As all operations are different, please understand that your specific operation may require additional adjustments in the maintenance and inspection process essential to permit the monitoring device to perform its intended function. Retain the Operation Manual and other important maintenance and service documents provided by 4B and have them readily available for people servicing your 4B equipment. Should you have any questions, please call the free 24-hour hotline number (309-698-5611).

6. Service Request

If you have questions or comments about the operation of your unit or require the unit to be serviced please call the 24-hour hotline number 309-698-5611, contact your local distributor, or use one of the ways available in our website www.go4b.com/usa. Please have available product part numbers, serial numbers, and approximate date of installation. In order to assist you, after the product has been placed into service, complete the online product registration section which is accessed via our website www.go4b.com/usa

⚠ WARNING

- Rotating machinery can cause serious injury or death
- Always lockout and tagout the machine prior to installation

PRODUCT OVERVIEW

The stainless-steel rub block inspection door simplifies the installation process for rub block sensors on bucket elevators and conveyors. During routine maintenance inspections, the hinged design allows for easy access to inspect both the belt and rub block for wear. If necessary, worn rub blocks can be easily replaced within a few minutes.

ADB series temperature sensors are supplied with 4B rub blocks. The sensor has been designed to allow the depth of the probe to be adjustable. When used with rub blocks, the probe should be fully inserted so that the tip of the probe touches the brass (Image A).

SENSOR SPECIFICATIONS

ADB temperature sensors are available with a standard NTC thermistor for 4B's Hotbus and Watchdog systems, or PT100 - RTD and 4-20 mA types for PLC and DCS systems. All types allow for continuous temperature monitoring.

ADB cable connections are not polarity sensitive, so no special connection requirements are needed.

4-20 mA Sensors - ADBMIL1V4C/D2

Supply Voltage -	24 VDC Nominal (15 to 28 VDC)
Overvoltage Rating -	CAT I
Reverse Polarity Protection -	Yes
Current at -40° F (-40° C) -	4 mA
Current at 248° F (120° C) -	20 mA
Temperature Accuracy -	Typical $\pm 1^{\circ}\text{F}$ (0.6°C) / Over Entire Range $\pm 5^{\circ}\text{F}$ (2.7°C)
Temp. Res. Over Current Loop -	0.09°F (0.05°C) - Default
Operating Temperature (Probe) -	Minimum: -40°F (-40°C) Maximum: 248°F (120°C)
Output Resolution (Typical) -	5 - 10 μA
Current Out of Range -	20.5 mA or < 4 mA
Body/Probe Material -	304 Stainless Steel
Fixing Thread -	1/8" NPT
Cable -	9 ft. (3 m) - 2 Conductor
Approvals -	CSA (Master Contract Ref: 212693) CSA Class II Div 1 Groups E, F and G - T4



**ADB 4-20 mA Sensor
(Purple Cable Wire)**

NTC Sensors - ADB20V3CAI/D2

Resistance at 25°C / 60°C / 90°C	10,000 Ohms / 3,043 Ohms / 1,264 Ohms
Sensing Voltage -	5 to 24 VDC
Current Draw -	1 mA (Max. Recommended)
Maximum Power -	120 mW at 77°F (25°C)
Body Housing -	304 Stainless Steel
Fixing Thread -	1/8" NPT
Cable -	9 ft. (3 m) - 2 Conductor
Operating Temp. -	Min. -22°F (-30°C) / Max. 220°F (105°C)
Approvals -	CSA Class II Div 1 (USA & Canada), ATEX & IECEX



**ADB NTC Sensor
(Blue Cable Wire)**

PT100 / RTD Sensors - ADB29V3CAI/D2

Resistance at -30°C / 60°C / 100°C	109.73 Ohms / 123.24 Ohms / 134.70 Ohms
Temp. Coefficient -	3850 PPM/K (385)
Sensing Voltage -	5 to 24 VDC
Current Draw -	1 mA (Max. Recommended)
Maximum Power	1 mW
Body Housing -	304 Stainless Steel
Fixing Thread -	1/8" NPT
Cable -	9 ft. (3 m) - 4 Conductor
Operating Temp. -	Min. -22°F (-30°C) / Max. 220°F (105°C)
Approvals -	CSA Class II Div 1 (USA & Canada), ATEX & IECEX



**ADB PT100 / RTD Sensor
(Yellow Cable Wire)**

NOTE

To determine your sensor type, the part number is located on a tag attached to the cable by the probe. 4B sensor types can also be determined by the cable wire color: Blue = NTC, Yellow = PT100 / RTD and Purple = 4-20 mA.

DIMENSIONS

ADB TEMPERATURE SENSOR -

ALL DIMENSIONS IN INCHES

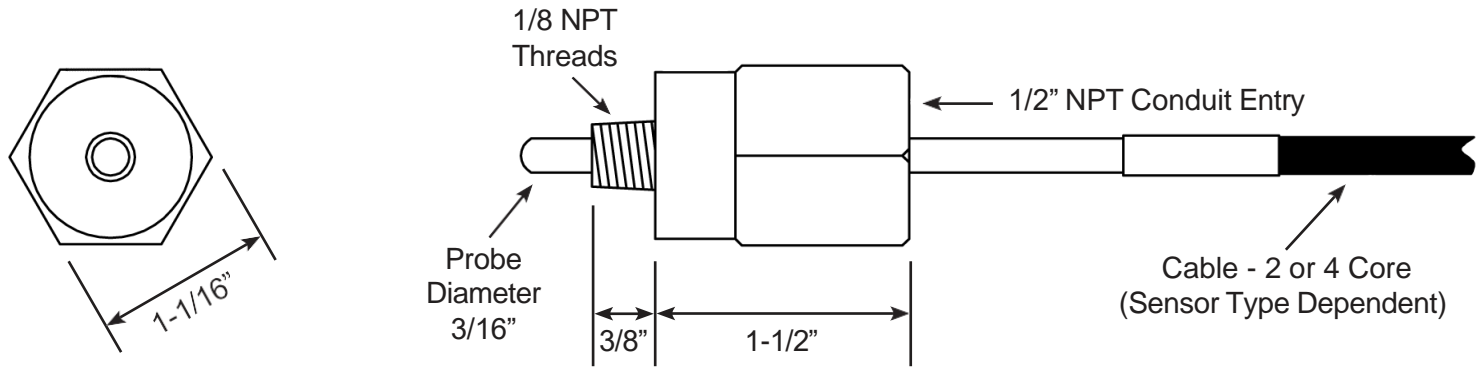

RUB BLOCK DOOR -

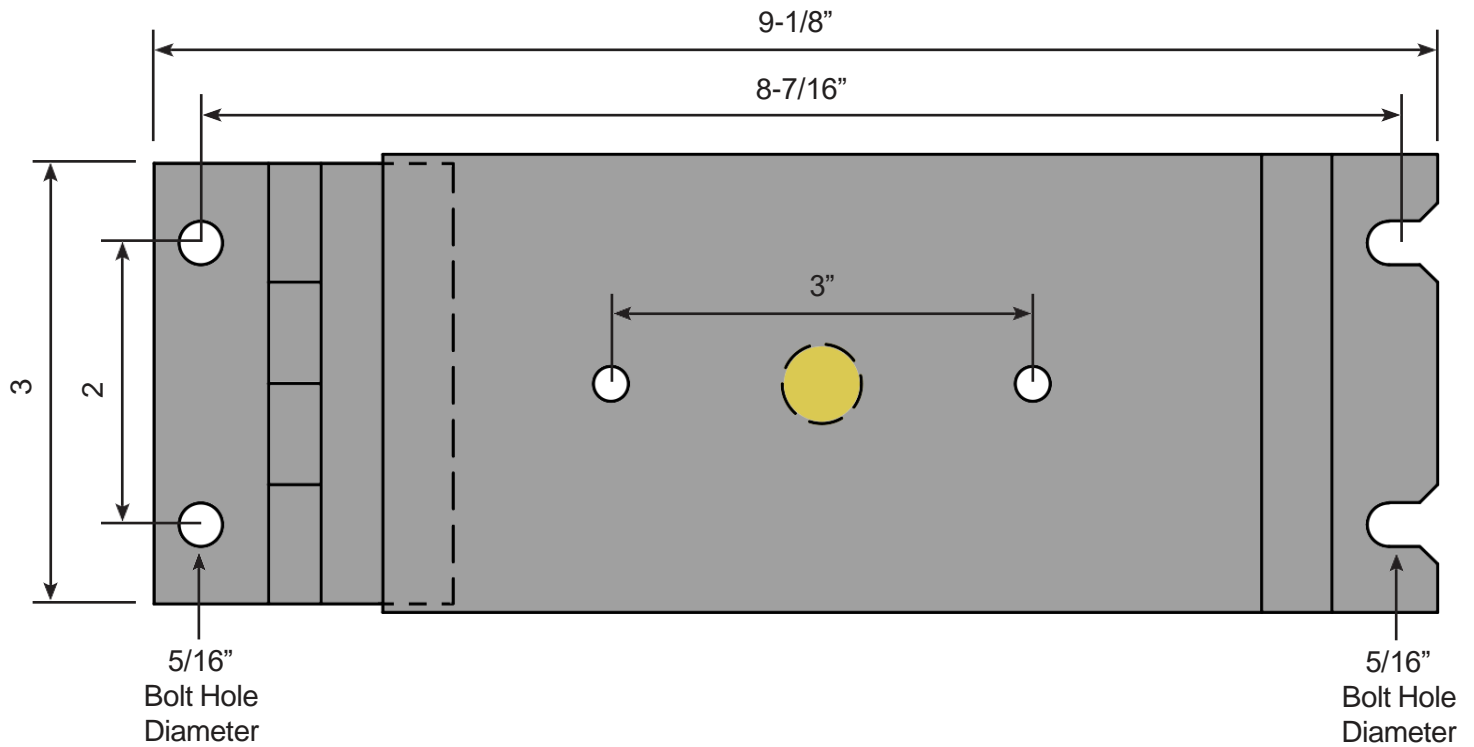

INSTALLATION

Align the rub block so that the belt is centered to either the left or right side of the sensor and the brass bolt attached to the block (Image C). Do not position the ADB temperature sensor directly in the path of the belt or the sensor may be damaged. The sensor is located in the middle of the brass block.

Using the inspection door as a template, mark the mounting locations for the four bolt holes. 3/8"-16 bolts with lock washers are recommended (bolt length will depend on the size of the casing). A cut out in the equipment casing measuring 4-1/2" x 2-1/2" is required for the brass rub block.

The bolts on the hinge side of the door will be fixed after installation. The bolts on the opposite or opening side of the door will use two nuts. One to keep the bolt in place (secured nut) when the door is opened, and the other (door nut) to allow the door to be opened for inspection or secured when the equipment is in use (Image D).

The ADB temperature sensor screws directly into the brass rub block and has an adjustable probe. When installing the sensor, make sure that the tip of the probe extends far enough to touch the brass end of the rub block (Images A & B). To adjust the depth of the probe, use the ADBW wrench. The maximum recommended torque for the probe nut is 18 in lb (2 Nm).

WARNING

4B recommends that you establish a preventative maintenance program that includes frequent inspections of the rub blocks to monitor wear. If a rub block shows wear, this indicates that a belt or pulley is misaligning and corrective action needs to be taken.

If a misalignment alarm is detected, be sure to inspect the rub block for wear. Correct the misalignment source, replace the rub block (if necessary), and test both the sensor and the system prior to running.

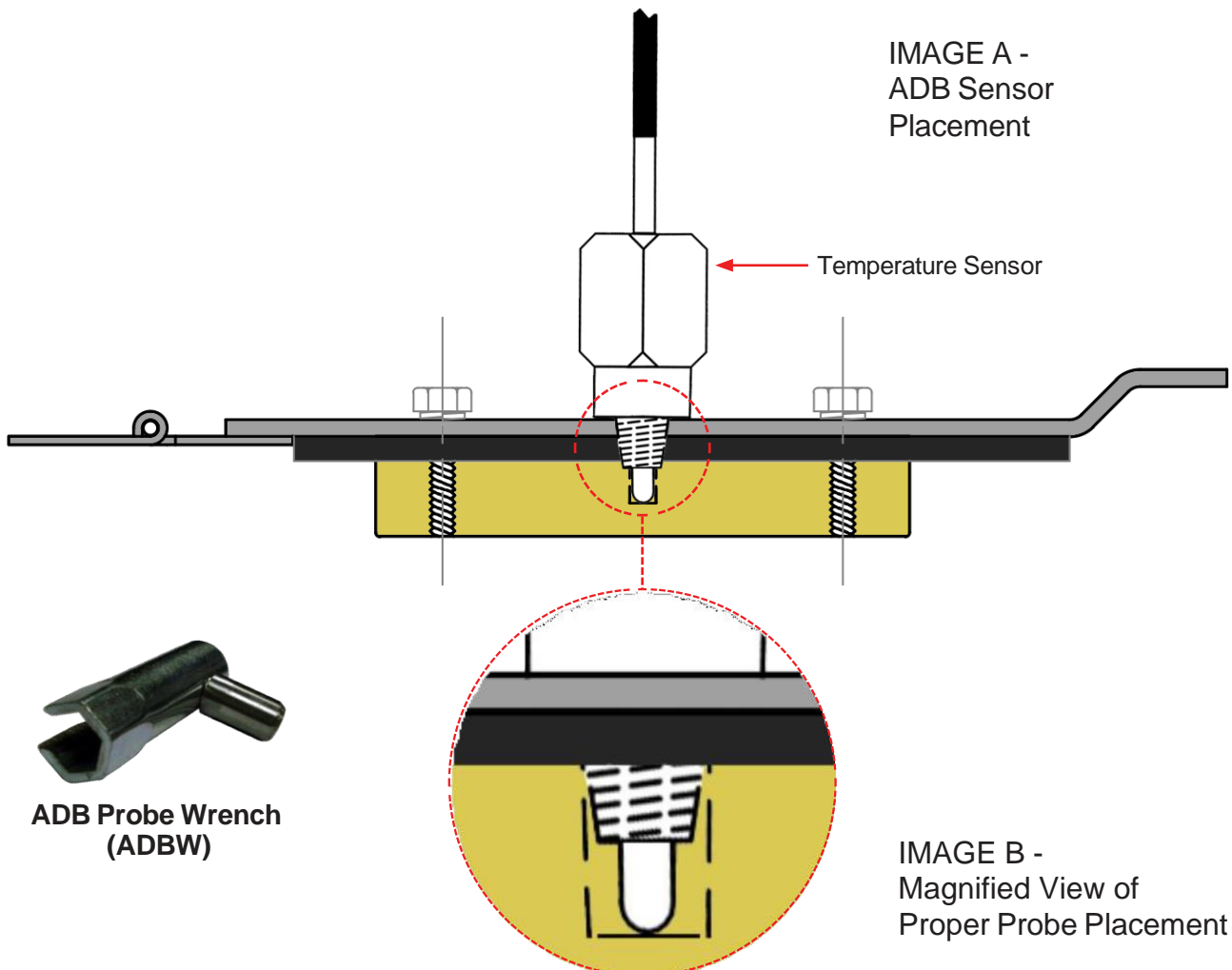

Rub Block Dimensions - L 4" x W 2" x D 3/4"

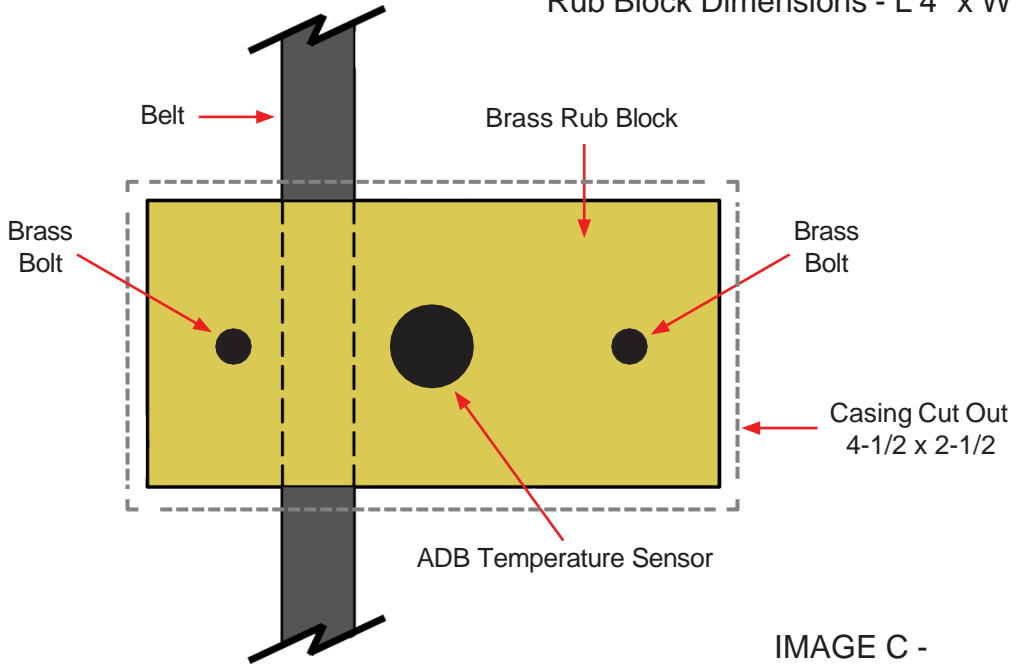

IMAGE C -
Sensor Alignment on Belt

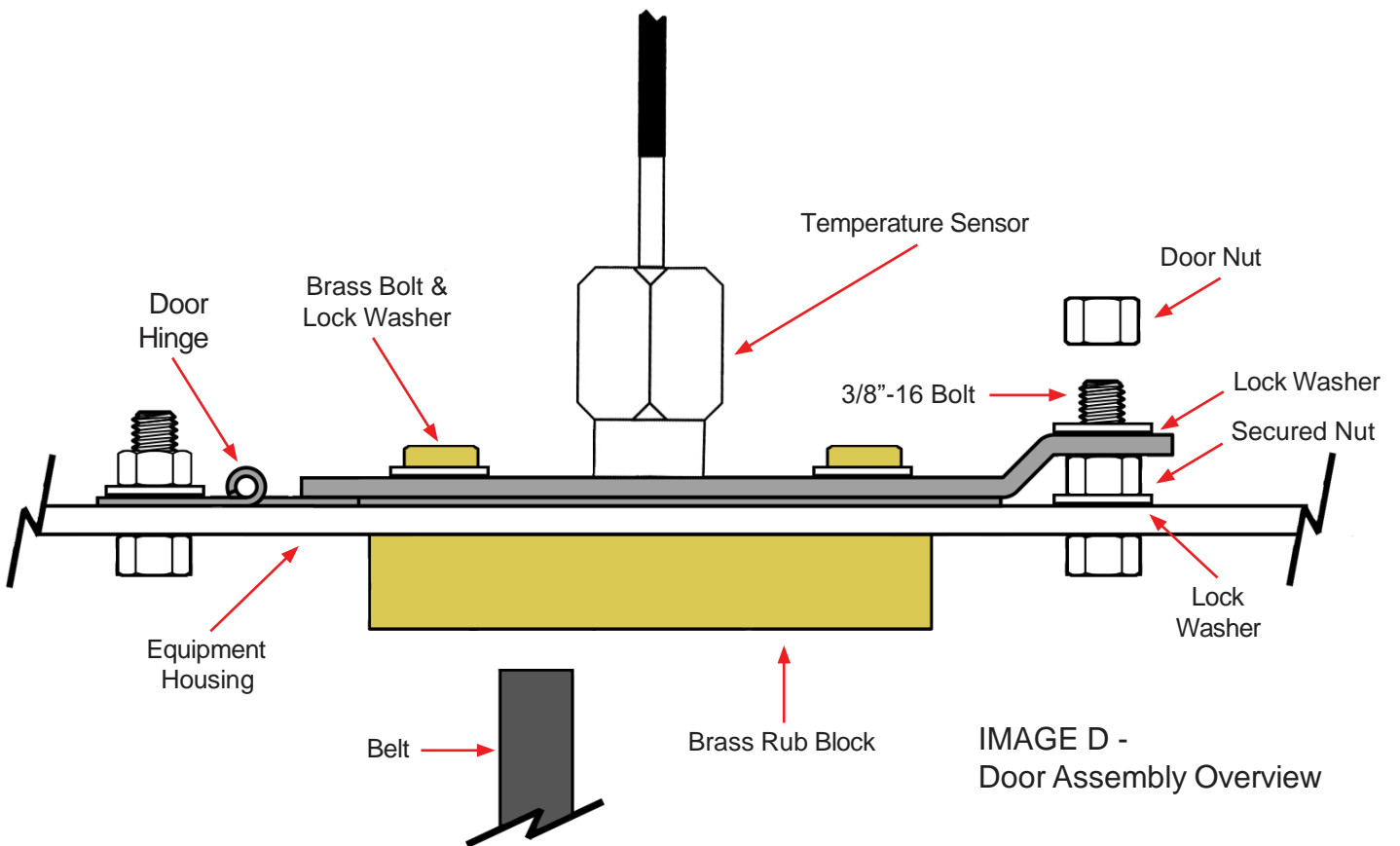

IMAGE D -
Door Assembly Overview

NOTE

The life of the rub block can sometimes be extended by turning it clockwise 180° around the ADB temperature sensor. Follow the installation instructions to ensure proper placement is maintained.

SENSOR WIRING AND DIAGRAMS

All wiring must be in accordance with local and national electrical codes and should be undertaken by an experienced and qualified electrician. All equipment should be properly grounded prior to operation.

Always use dust/liquid tight flexible metal conduit with approved fittings to protect the sensor cables. Use rigid metal conduit to protect the cables from the sensors to the control unit. Conduit systems can channel water due to ingress and condensation directly to sensors and sensor connections which over time will adversely affect the performance of the system. As such, the installation of low point conduit drains is recommended for all sensors.

All ADB sensors are non-polarity sensitive, however 4B recommends wiring the sensors as outlined below. For PT100 - RTD sensors, the resistance compensation wire used will be dependent on the application. For example some PLC's may require three wires, others may use all four.

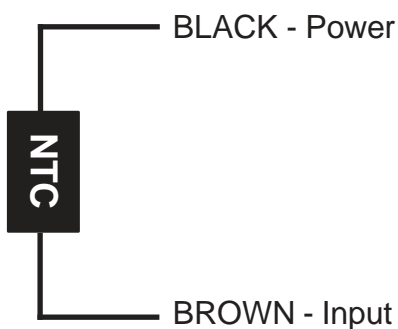

NTC WIRING

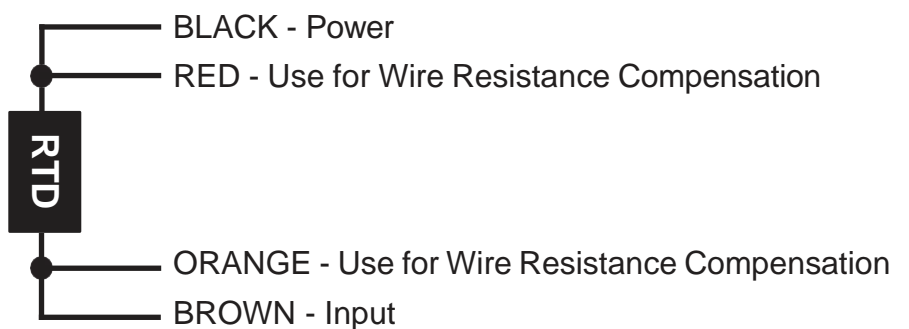

PT100 - RTD WIRING

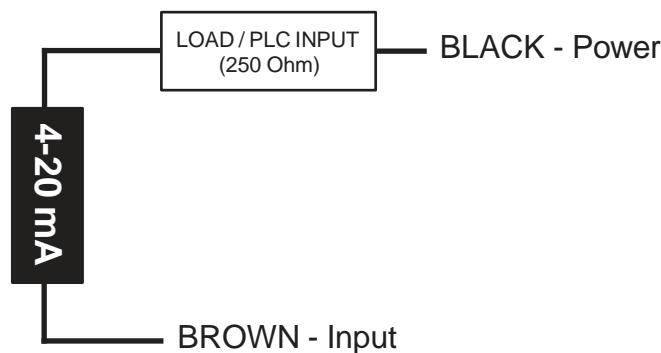

4-20 mA WIRING

WARNING

Do not wire the sensor across the voltage source directly. Always ensure that the sensor is wired into a signal conditioning circuit for the temperature measurement. Please note that if the power applied across the sensor exceeds the specified maximum rated power or current, then the sensor may be damaged beyond repair. When properly wired to 4B controllers, the power rating across the sensors is kept at a safe level.

- 1) Check that the unit is correctly installed.
- 2) 4B's ADB Sensor Tester can be used as a diagnostic tool to verify the alarm and shutdown sequences of the control unit are functioning as expected.
- 3) Contact 4B for any questions regarding installation issues if the sensor does not perform as expected.



ADB Bearing Sensor Tester

The ADB Sensor Tester has been designed to test 4B adjustable depth bearing (ADB) temperature sensors in the field. This handheld test unit features an integrated heating block specifically designed to have a 4B ADB sensor directly inserted. With integral controls and temperature display, the unit heats the sensor to the desired trip point and allows quick and easy real-life testing of the sensor and temperature monitoring system.

During planned maintenance or periodic testing, the ADB Sensor Tester can be used as a diagnostic tool to verify the alarm and shutdown sequences of the control unit are functioning as expected. To test, the heater block should be set above the control units alarm operating temperature. Remove the ADB bearing sensor probe from the housing and insert it into the heater block. As the heater block reaches the alarm temperature, the ADB sensor will relay this data to the control unit, allowing you to verify that the alarm and shutdown sequences run as expected. When testing is complete, reinstall the probe back into the bearing housing.



WARNING

If the system does not immediately shutdown as expected or alarm as required, then remove the machine from service until the problem has been diagnosed and corrected.

PRODUCT WARRANTY

1. EXCLUSIVE WRITTEN LIMITED WARRANTY

ALL PRODUCTS SOLD ARE WARRANTED BY THE COMPANY 4B COMPONENTS LIMITED AND 4B BRAIME COMPONENTS LIMITED HEREIN AFTER REFERRED TO AS 4B TO THE ORIGINAL PURCHASER AGAINST DEFECTS IN WORKMANSHIP OR MATERIALS UNDER NORMAL USE FOR ONE (1) YEAR AFTER DATE OF PURCHASE FROM 4B. ANY PRODUCT DETERMINED BY 4B AT ITS SOLE DISCRETION TO BE DEFECTIVE IN MATERIAL OR WORKMANSHIP AND RETURNED TO A 4B BRANCH OR AUTHORIZED SERVICE LOCATION, AS 4B DESIGNATES, SHIPPING COSTS PREPAID, WILL BE, AS THE EXCLUSIVE REMEDY, REPAIRED OR REPLACED AT 4B'S OPTION.

2. DISCLAIMER OF IMPLIED WARRANTY

NO WARRANTY OR AFFIRMATION OF FACT, EXPRESSED OR IMPLIED, OTHER THAN AS SET FORTH IN THE EXCLUSIVE WRITTEN LIMITED WARRANTY STATEMENT ABOVE IS MADE OR AUTHORIZED BY 4B. 4B SPECIFICALLY DISCLAIMS ANY LIABILITY FOR PRODUCT DEFECT CLAIMS THAT ARE DUE TO PRODUCT MISUSE, ABUSE OR MISAPPLICATIONS, AS AUTHORIZED BY LAW, 4B SPECIFICALLY DISCLAIMS ALL WARRANTIES THAT THE PRODUCT IS FIT OR MERCHANTABILITY FOR A PARTICULAR PURPOSE.

3. NO WARRANTY "BY SAMPLE OR EXAMPLE"

ALTHOUGH 4B HAS USED REASONABLE EFFORTS TO ACCURATELY ILLUSTRATE AND DESCRIBE THE PRODUCTS IN ITS CATALOGS, LITERATURE, AND WEBSITES, SUCH ILLUSTRATIONS AND DESCRIPTIONS ARE FOR THE SOLE PURPOSE OF PRODUCT IDENTIFICATION AND DO NOT EXPRESS OR IMPLY A WARRANTY AFFIRMATION OF FACT, OF ANY KIND OR A WARRANTY OR AFFIRMATION OF FACT THAT THE PRODUCTS WILL CONFORM TO THEIR RESPECTIVE ILLUSTRATIONS OR DESCRIPTIONS. 4B EXPRESSLY DISCLAIMS ANY WARRANTY OR AFFIRMATION OF FACT, EXPRESSED OR IMPLIED, OTHER THAN AS SET FORTH IN THE EXCLUSIVE WRITTEN LIMITED WARRANTY STATEMENT ABOVE, INCLUDING, WITHOUT LIMITATION, THE IMPLIED WARRANTIES OF MERCHANTABILITY AND FITNESS FOR A PARTICULAR PURPOSE.

4. LIMITATION OF DAMAGES

ANY LIABILITY FOR CONSEQUENTIAL, INCIDENTAL, SPECIAL, EXEMPLARY, OR PUNITIVE DAMAGES, OR FOR LOSS OF PROFIT WHETHER DIRECT OR INDIRECT, IS EXPRESSLY DISCLAIMED.

4B is the worldwide leading manufacturer of high-quality, technologically advanced material handling and electronic components.



4B Locations Around the World



USA

4B Components Ltd.
625 Erie Avenue
Morton, IL 61550
Tel: +1 (309) 698-5611

United Kingdom

4B Braime Components Ltd.
Hunslet Road
Leeds, LS10 1JZ
Tel: +44 (0) 113 246 1800

Thailand

4B Asia Pacific
Build No.899/1 Moo 20
Soi Chongsiri, Bangplee-Tam Ru Road
Tanbon Bangpleeyai, Amphur Bangplee
Samutprakarn 10540
Tel: +66 (0) 2 173-4339

France

4B France
35 bis, rue du 8 mai 1945,
Villers Bretonneux, F-80800
Tel: +33 (0) 3 22 42 32 26

Germany

4B Deutschland
35 bis, rue du 8 mai 1945,
Villers Bretonneux, F-80800
France
Tel: +49 (0) 2333 601681

South Africa

4B Africa
14 Newport Business Park
Mica Drive, Kya Sand
2163 Johannesburg
Tel: +27 (0) 11 708 6114

Australia

4B Australia
Building 1, 41 Bellrick St,
Acacia Ridge 4110,
Queensland
Tel: +61 (0)7 3216 9365

China

4B China
F1, Building 5A,
8 West Lake Road Wujin High &
New Technology Develop. Zone
Changzhou 213164
Jiangsu Province
Tel: +86-136 0160 9266

United Arab Emirates

4B Braime Components Limited
Sharjah International Airport Free Zone
Saif Zone, Y Building, Office no. Y-44A
P.O Box: SHJ-0., UAE reg. no. 23784
Tel: +971 (0) 6 5212 044