

VIBMIL

VIBMIL

Vibration Sensor



APPLICATION

VIBMIL is a vibration sensor designed for continuous monitoring of vibration levels in industrial environments. It is current loop powered accelerometer and delivers accurate vibration RMS velocity using a 4-20 mA output. Built with a stainless-steel enclosure, including a 3/4" NPT thread for conduit connection. The VIBMIL can be supplied with optional inbuilt NTC or PT100 temperature sensors.

METHOD OF OPERATION

The VIBMIL is equipped with female 1/4"-28 UNF female mounting thread, allowing the use of a screw, stud, or mounting stud to secure the sensor to the desired application.

The sensor is supplied with a 1/4"-28 UNF set screw as standard. Optional converters to M8 and M6 male threads are available.

To achieve maximum sensitivity, mount the sensor vertically along the Y-axis of the machinery.

To ensure accurate readings and proper functioning of the VIBMIL, securely fix it to a level surface during installation.

Implement the 2 wire, loop powered accelerometer into the desired control system and measure the linear output from 4 – 20mA proportional to the sensors measuring range.



FEATURES

- ▶ Robust, compact, IP66 Stainless Steel enclosure
- ▶ Monitors RMS velocity in mm/s
- ▶ Measuring range 0-25 mm/s standard, and 0-50 mm/s special request.
- ▶ Can also monitor surface temperature with optional NTC or PT100 temperature sensor
- ▶ 2 wire 4-20mA loop powered sensor
- ▶ 3/4" NPT conduit fitting
- ▶ 1/4" – 28 Female UNF mounting thread.
- ▶ ATEX, IECEx, UKEx Zone 20 Approved
- ▶ Class II Div 1 Approved

PART NUMBERS/ACCESSORIES

- ▶ VIBMIL21V4CAI - VIBMIL Vibration Sensor 1/4"-28UNF – No Temp. - NRTL / ATEX / IECEx / UKEx
- ▶ VIBMIL21NV4CAI - VIBMIL Vibration Sensor 1/4"-28UNF - NTC Temp. Sensor - NRTL / ATEX / IECEx / UKEx
- ▶ VIBMIL21PV4CAI - VIBMIL Vibration Sensor 1/4"-28UNF - PT100 Temp. Sensor - NRTL / ATEX / IECEx / UKEx
- ▶ VIBMILM6 - VIBMIL 1/4"-28 UNF Male to M6 Male thread Adaptor
- ▶ VIBMILM8 - VIBMIL 1/4"-28 UNF Male to M8 Male thread Adaptor

VIBMIL

WIRE DESCRIPTION

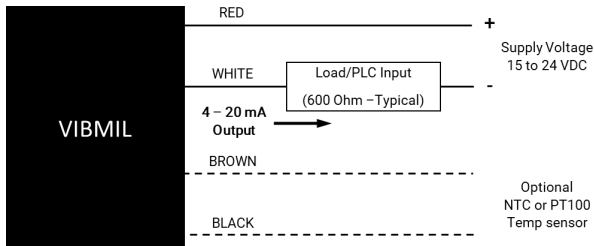

DIMENSIONS

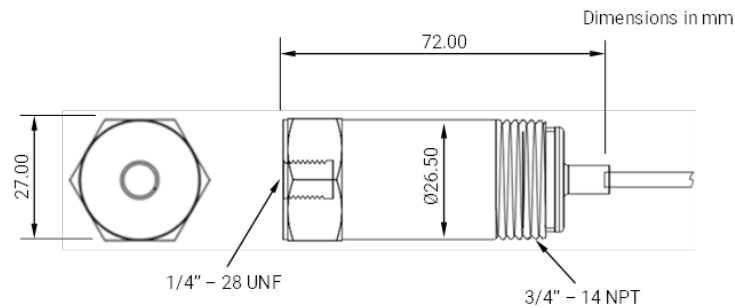

TECHNICAL SPECIFICATIONS

Power Supply	+15 VDC to +24 VDC (+10%)
Power Dissipation	0.56 Watts Max
Measuring Range	<ul style="list-style-type: none"> • 0 – 25 mm/s RMS Velocity (VIBMILx1xVxx) • 0 – 50 mm/s RMS Velocity (VIBMILx2xVxx) (Depending on the model)
Frequency Range	4 – 20 mA proportional to Measuring Range
Maximum Load	600 Ohms at 24 VDC Supply Voltage
Optional Temp Sensor	NTC (VIBMILxxNVxx) or PT100 (VIBMILxxPVxx)
Power-on Time	< 10 sec
Operating Temp	-40 °C to +50 °C
Dimensions	Height 72 mm x Width 27 mm
Mounting Thread	1/4"-28 UNF female thread (supplied with 1/4"-28 UNF set screw)
Mounting Torque	8 Nm
Housing Material	Stainless Steel
Cable	3m (9.8 ft) long, with 2 or 4 cores 24 AWG
Approvals	ATEX, IECEx, UKEx Zone 20 Class II Div 1 Groups E, F & G (US & Canada)