

DO NOT SCALE

IF IN DOUBT - ASK

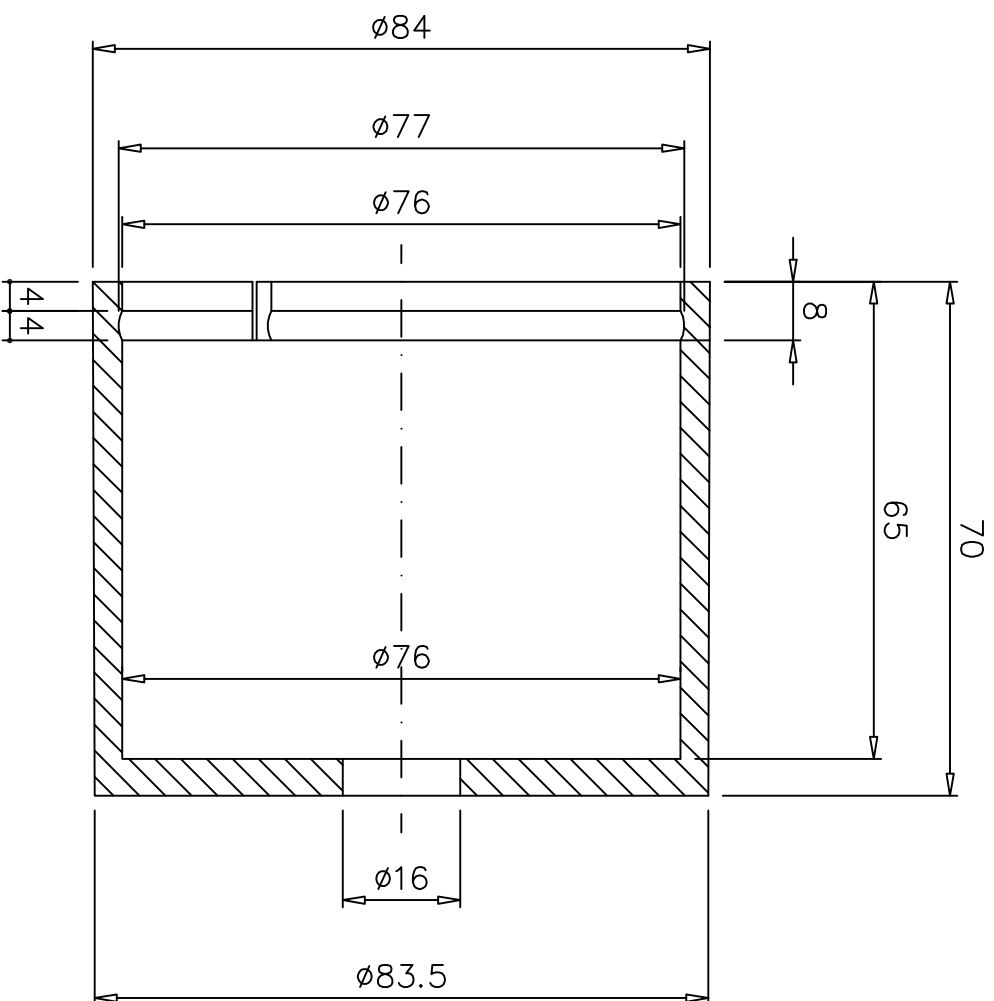

**Sez. A-A**

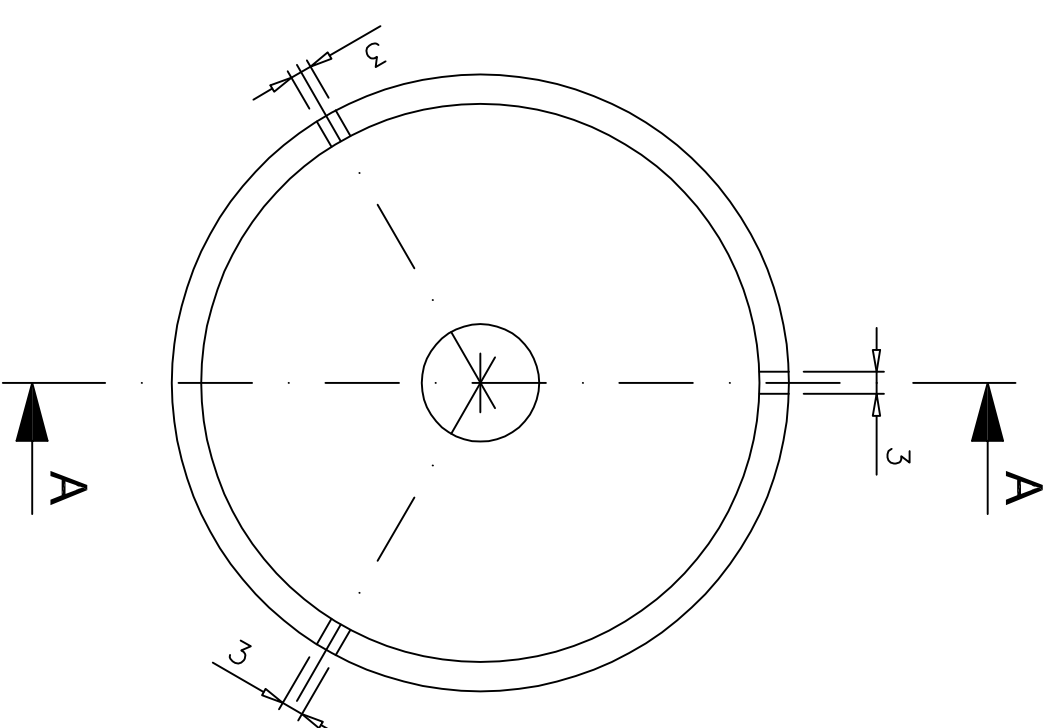

UNSPECIFIED TOLERANCES
WHOLE NUMBERS $\pm 0.5\text{mm}$
ONE DECIMAL PLACE $\pm 0.1\text{mm}$
TWO DECIMAL PLACES $\pm 0.05\text{mm}$
ANGULAR $\pm 0.25^\circ$

FIRST ANGLE PROJECTION
AUTOCAD DRG MANUAL CHANGES PROHIBITED

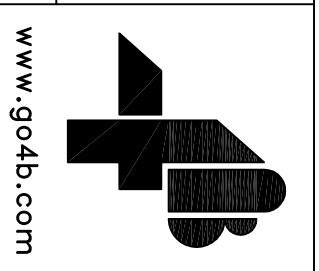

CUSTOMER	
Material Nylon 6	CUSTOMER PT No CAP
DRAWN BY DATE	CHECKED BY DATE
DRAWING NO	SCALE REV

[www.go4b.com](http://www.go4b.com)