



Binswitch Elite

CAPACITANCE POINT LEVEL SENSOR



INSTALLATION INSTRUCTIONS

OPERATION MANUAL

Part No. BSE15V10AI/x/B5



www.go4b.com

TABLE OF CONTENTS

CUSTOMER SAFETY RESPONSIBILITIES	Page 3 - 4
PRODUCT OVERVIEW	Page 5
SPECIFICATIONS	Page 5
APPROVALS	Page 6
DIMENSIONS	Page 6
INSTALLATION	Page 7
WIRING DIAGRAMS	Page 8
SENSOR CALIBRATION	Page 9
TESTING & COMMISSIONING	Page 10
TROUBLESHOOTING GUIDE	Page 10
BINSWITCH ACCESSORIES	Page 10
PRODUCT WARRANTY	Page 11

Dear 4B Customer:

Congratulations on your purchase. 4B appreciates your business and is pleased you have chosen our products to meet your needs.

Please read in its entirety and understand the literature accompanying the product before you place the product into service. Please read the safety precautions carefully before operating the product. With each product you purchase from 4B, there are some basic but important safety considerations you must follow to be sure your purchase is permitted to perform its design function and operate properly and safely, giving you many years of reliable service. Please read and understand the Customer Safety Responsibilities listed below. Failure to follow this safety directive and the Operation Manuals and other material furnished or referenced, may result in serious injury or death.

SAFETY NOTICE TO OUR CUSTOMERS

- A. In order to maximize efficiency and safety, selecting the right equipment for each operation is vital. The proper installation of the equipment, and regular maintenance and inspection is equally important in continuing the proper operation and safety of the product. The proper installation and maintenance of all our products is the responsibility of the user unless you have asked 4B to perform these tasks.
- B. All installation and wiring must be in accordance with Local and National Electrical Codes and other standards applicable to your industry. The installation of the wiring should be undertaken by an experienced and qualified professional electrician. Failure to correctly wire any product and/or machinery can result in the product or machine failing to operate as intended, and can defeat its design function.
- C. Periodic inspection by a qualified person will help assure your 4B product is performing properly. 4B recommends a documented inspection at least annually and more frequently under high use conditions.
- D. Please see the last page of this manual for all warranty information regarding this product.

CUSTOMER SAFETY RESPONSIBILITIES

1. READ ALL LITERATURE PROVIDED WITH YOUR PRODUCT

Please read all user, instruction and safety manuals to ensure that you understand your product operation and are able to safely and effectively use this product.

2. YOU BEST UNDERSTAND YOUR NEEDS

Every customer and operation is unique, and only you best know the specific needs and capabilities of your operation. Please go to www.go4b.com or call the 24-hour hotline at +1-309-698-5611 for assistance with any questions about the performance of products purchased from 4B. 4B is happy to discuss product performance with you at any time.

3. SELECT A QUALIFIED AND COMPETENT INSTALLER

Correct installation of the product is important for safety and performance. If you have not asked 4B to perform the installation of the unit on your behalf, it is critical for the safety of your operation and those who may perform work on your operation that you select a qualified and competent electrical installer to undertake the installation. The product must be installed properly to perform its designed functions. The installer should be qualified, trained, and competent to perform the installation in accordance with local and national electrical codes, all relevant regulations, as well as any of your own standards and preventive maintenance requirements, and other product installation information supplied with the product. You should be prepared to provide the installer with all necessary installation information to assist in the installation.

4. ESTABLISH AND FOLLOW A REGULAR MAINTENANCE AND INSPECTION SCHEDULE FOR YOUR 4B PRODUCTS

You should develop a proper maintenance and inspection program to confirm that your system is in good working order at all times. You will be in the best position to determine the appropriate frequency for inspection. Many different factors known to the user will assist you in deciding the frequency of inspection. These factors may include but are not limited to weather conditions; construction work at the facility; hours of operation; animal or insect infestation; and the real-world experience of knowing how your employees perform their jobs. The personnel or person you select to install, operate, maintain, inspect or perform any work whatsoever, should be trained and qualified to perform these important functions. Complete and accurate records of the maintenance and inspection process should be created and retained by you at all times.

5. RETAIN AND REFER TO THE OPERATION MANUAL FOR 4B'S SUGGESTED MAINTENANCE AND INSPECTION RECOMMENDATIONS

As all operations are different, please understand that your specific operation may require additional adjustments in the maintenance and inspection process essential to permit the monitoring device to perform its intended function. Retain the Operation Manual and other important maintenance and service documents provided by 4B and have them readily available for people servicing your 4B equipment. Should you have any questions, please call go to www.go4b.com or call the 24-hour hotline at +1-309-698-5611.

6. SERVICE REQUEST

If you have questions or comments about the operation of your unit or require the unit to be serviced please contact the 4B location who supplied the product or send your request go to www.go4b.com or call the 24-hour hotline at +1-309-698-5611. Please have available product part numbers, serial numbers, and approximate date of installation. In order to assist you, after the product has been placed into service, complete the online product registration section which is accessed via our website www.go4b.com.

WARNING

Always lockout and tagout machinery prior to installation

PRODUCT OVERVIEW

The Binswitch Elite sensor detects level or plug situations for bulk granular solids or liquids in tanks, bins, or silos and can be used as a plug or choke detector in chutes, conveyors and elevator legs. The sensor is fully encapsulated in a 30 mm diameter nylon body that is corrosion and abrasion resistant, dust-tight and waterproof. The Binswitch Elite operates by detecting capacitance change when material is present. A user selectable relay output can be magnetically calibrated to be normally energized or de-energized, and during calibration the sensor automatically compensates for material build up, shields or attached metal probes.

SPECIFICATIONS

Model Power Supply -	24 to 240 VDC / VAC
Operating Temperature -	-15°C (5°F) to +50°C (122°F)
Sensing Range -	25 mm (1 inch) maximum
Output Modes -	Energized: output on (N/O and common contacts closed) De-energized: output off (N/C and common contacts closed)
Output -	SPCO relay, 60V ac/dc 3A max.
Calibration Controls -	1. Magnetic sensitivity control point (bin must be empty when calibrating) 2. Magnetic calibration point (bin must be empty when calibrating)
Blue LED Indication -	On - normally energized (see sensor calibration for details)
Cable -	5 wire NOTE: custom cable lengths available designated by /xx at the end of the part number; e.g. BSE15V10AI/5/B5 would have a 5m cable.
Enclosure -	GRILON POLYAMIDE
Protection -	IP66

APPROVALS

ATEX	Baseefa12ATEX0226X ⚡ 1G Ex ma IIC T4 Ga ⚡ 1D Ex ma IIIC T ₂₀₀ 110°C Da Tamb -15°C to 50°C, IP66
IECEX	IECEX BAS 12.0118X Ex ma IIC T4 Ga Ex ma IIIC T ₂₀₀ 110°C Da Tamb= -15°C to +50°C IP66
UKEx	BAS21UKEX0315X ⚡ 1G Ex ma IIC T4 Ga ⚡ 1D Ex ma IIIC T ₂₀₀ 110°C Da Tamb -15°C to 50°C, IP66
EACEx	RU C-GB.Aд07.B.02815/20 ⚡ 0 Ex ma IIC T4 Ga X ⚡ Ex ma IIIC T200110°C Da X OT -15 до +50 IP66
CCC	CQC-2020012315348849 Ex maD A20 IP66 T110°C
CSA (North America)	Class II, Division 1 Groups E, F and G

DIMENSIONS

Note:
Main dimensions in mm.

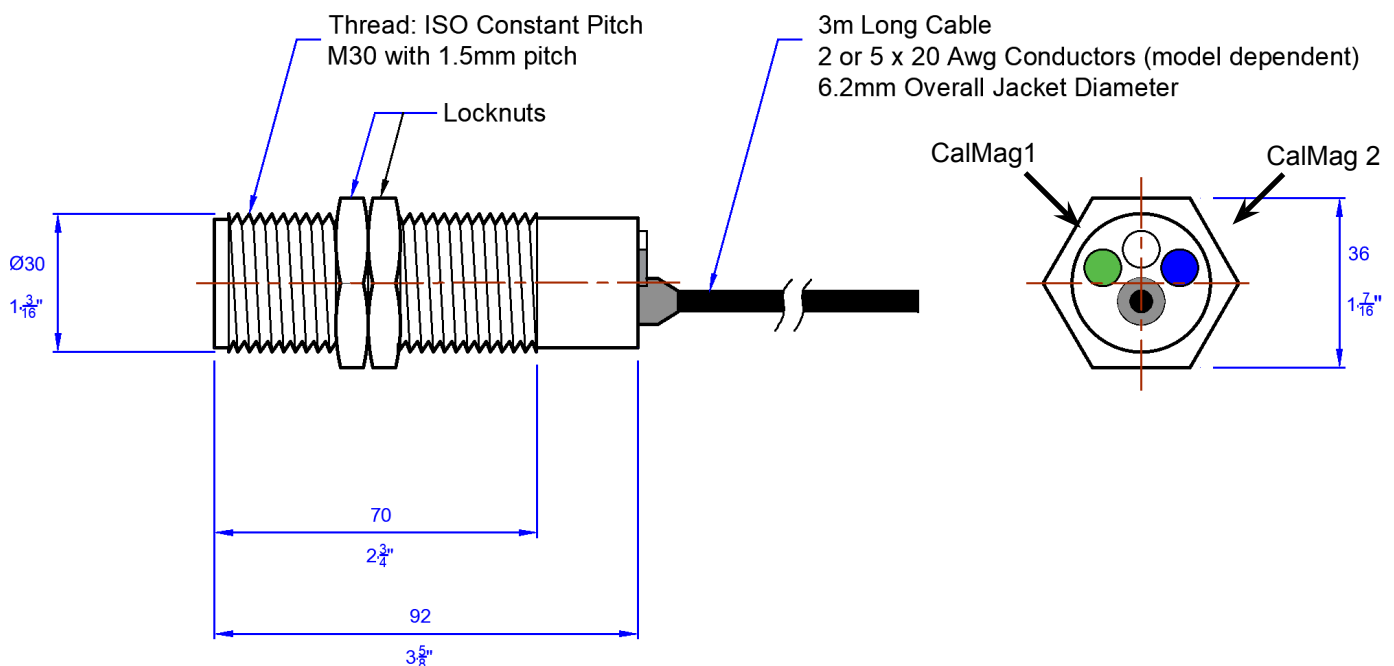

NOTE: custom cable lengths available designated by /xx at the end of the part number; e.g. BSE15V10AI/10 would have a 10m cable.

INSTALLATION

The Binswitch Elite may be mounted horizontally or vertically. 4B offers BAS3 mounting accessory for this. The end of the sensor must be at least 25mm (one inch) from the bin wall or other metalwork.

It is important that the Binswitch is not located in the direct flow path of any abrasive material. However, if the Binswitch must be located in the path of an abrasive material, use in conjunction with the BAS3 (Binswitch Abrasion Shield).

Binswitch Elite mounting method is available figure A below:

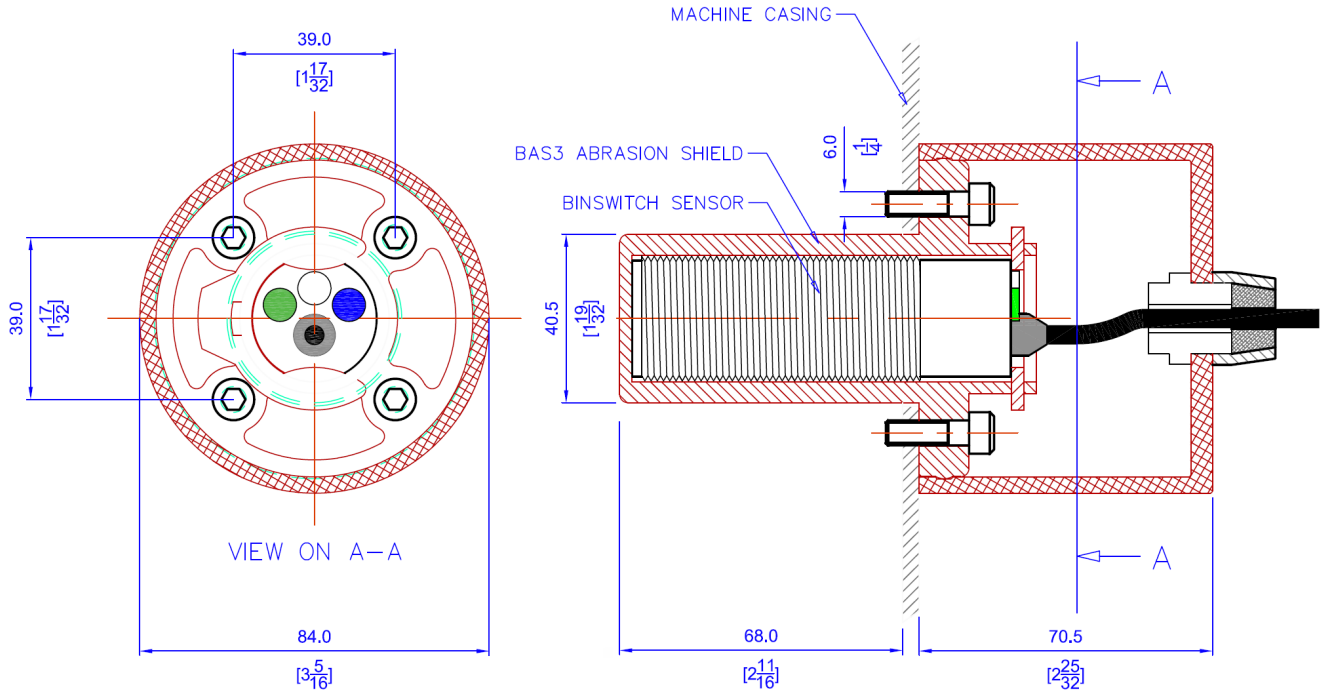

Fig. A -

Cut and drill holes as shown and attach brasion shield (BAS3) using four M6 bolts. Slide Binswitch into position and secure with a clip and cover (part of the BAS3 assembly).

WIRING DIAGRAMS

All wiring must be in accordance with local and national electrical codes and should be undertaken by an experienced and qualified electrician.

BSE15V10AI - 5 Wire

24 to 240
VAC / VDC
(Universal Supply)

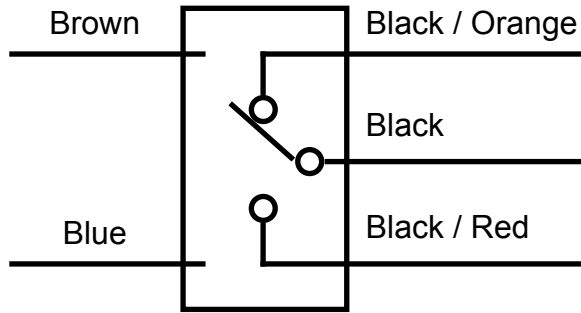

Shown In De-Energized State

NOTE

SPCO output relay is rated at 60V ac/dc 3A max.

SENSOR CALIBRATION

1. The unit must be installed before calibration takes place. Connect the Binswitch to power and a suitable control unit
 2. Check that the tip of the Binswitch is not covered or obstructed.
 3. On the rear of the Binswitch there are two calibration points/LEDS. Magnets are used to programme required functions. The magnets are simply applied below the LED windows on the rear of the unit (CalMag1 - green LED; CalMag2 - blue LED). A CalMag twin magnetic programmer is supplied with each sensor. See Figure B for more information.
3. Set output mode
- a. **Decide:** Do you need the output to be **normally energised** or **normally de-energised** when **NO** material present?
 - b. With power ON, hold the CalMag programmer onto CalMag1 & CalMag2 points on the rear of the Binswitch sensor. The Green LED will glow static, the blue LED will flash at approximately 1 second intervals.
 - c. For the energised mode (output ON with NO material present), remove the magnets when the blue LED is ON.
 - d. For the de-energised mode (output OFF with NO material present), remove the magnets when the blue LED is OFF.
 - e. Wait for approximately 10 seconds for the green LED to turn OFF. The sensor output mode has been set and the sensitivity can now be programmed.
4. Set sensitivity and range
- a. The Binswitch has a typical programmable sensing range of approximately 0 to 25mm increasing or decreasing in 24 steps, LED's will flash rapidly at minimum or maximum range.
 - b. With material to be detected present proceed as follows:
 - Increase sensitivity: - With power ON, hold one of the CalMag magnets on to CalMag2 LED window (blue). The green LED will flash and start flashing rapidly when maximum range/sensitivity is achieved.
 - Decrease sensitivity: - With power ON, hold one of the CalMag magnets on to CalMag1 LED window (green). The green LED will flash and start flashing rapidly when minimum range/sensitivity is achieved.
 - c. Use this method if you selected the de-energised mode (3.d). Decrease range/sensitivity (Calmag1) green LED, until the output 'just' switches off , increase the range/sensitivity (CalMag2) blue LED, until the output 'just' switches on,increase the range/sensitivity by one further increment of (Cal-Mag2).
 - d. Use this method if you selected the energised mode (3.c). Decrease range/sensitivity (Calmag1) green LED, until the output 'just' switches on, increase the range/sensitivity (CalMag2) blue LED, until the output 'just' switches off, increase the range/sensitivity by one further increment of (Cal-Mag2).
5. Sensor is successfully calibrated

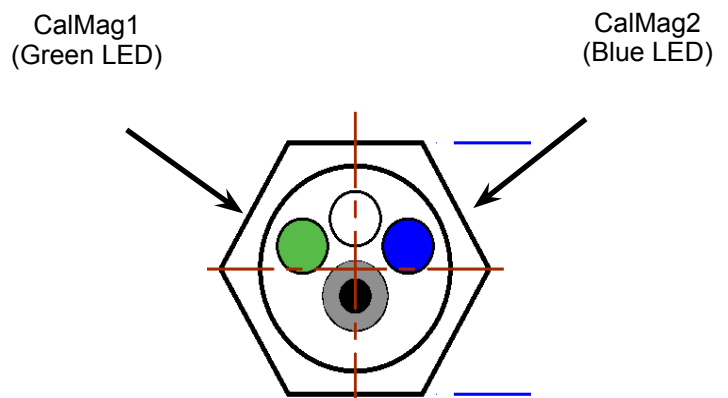

Fig. B -
Calibration points positions

NOTE

If the material being monitored creates dust, you may need to re-calibrate the sensor. Dust build up on the Binswitch will affect the initial calibration. **DO NOT** remove the Binswitch and clean off the dust. *Always check that the Binswitch detects material after the sensitivity has been adjusted.*

TESTING AND COMMISSIONING

1. Check that the unit is correctly installed (see standard wiring diagram).
2. After going through the sensor calibration steps, the green LED should be “ON” if calibrated to be NORMALLY ENERGIZED or “OFF” if NORMALLY DE-ENERGIZED.
3. Introduce material to the Binswitch. If calibrated correctly, the Binswitch will activate when material has been detected. Machinery shut down will depend on your specific monitoring setup. 4B recommends an instant shutdown when maximum fill level or a plug condition has been detected.

⚠ WARNING

If the system does not immediately shutdown as expected or alarm as required, then remove the machine from service until the problem has been diagnosed and corrected.

TROUBLESHOOTING GUIDE

FAULT	REMEDY
Unexpected Operation	Re-calibrate sensor, if problem continues contact 4B.
False / Inconsistent Readings	<ol style="list-style-type: none">1. Check that sensor is not in the direct flow of material, and remove from flow if necessary.2. If sensor is coated in dust, re-calibrate by following calibration instructions.
Sensor Not Detecting Material	<ol style="list-style-type: none">1. If monitoring different types of materials, calibrate the sensor sensitivity to the lightest material being monitored.2. Re-calibrate sensor, if problem continues contact 4B.

BINSWITCH ACCESSORIES

BAS3
Nylon Abrasion Shield

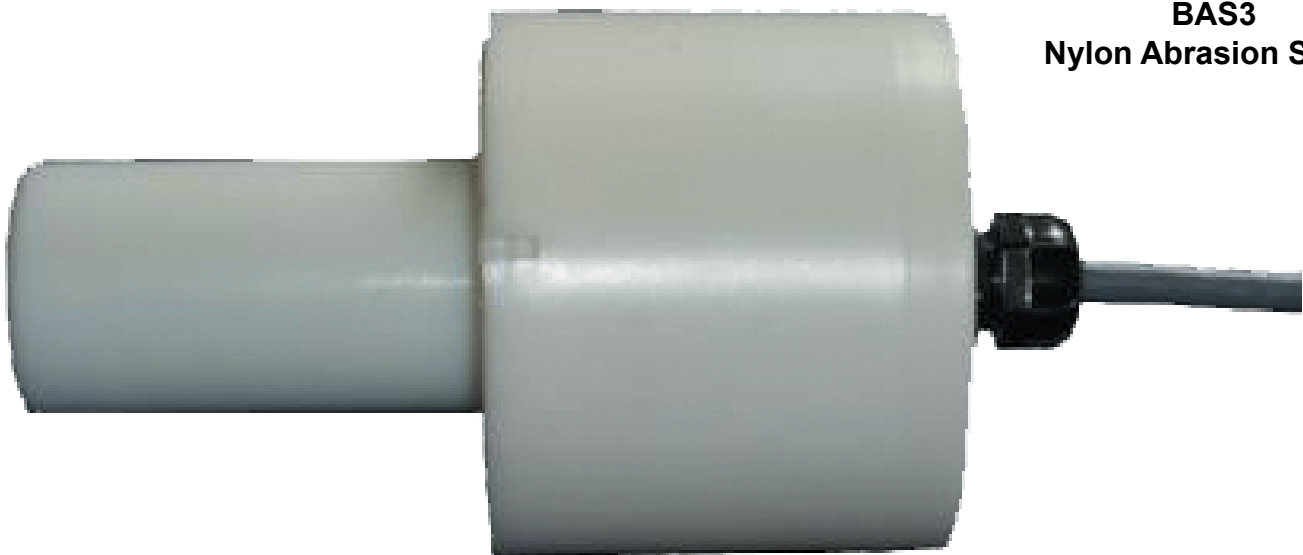

PRODUCT WARRANTY

1. EXCLUSIVE WRITTEN LIMITED WARRANTY

All products sold are warranted by the company 4B Components Limited, 4B Braime Components Limited, and 4B France herein after referred to as 4B to the original purchaser against defects in workmanship or materials under normal use for one (1) year after date of purchase from 4B. Any product determined by 4B at its sole discretion to be defective in material or workmanship and returned to a 4B branch or authorized service location, as 4B designates, shipping costs prepaid, will be, as the exclusive remedy, repaired or replaced at 4B's option.

2. DISCLAIMER OF IMPLIED WARRANTY

No warranty or affirmation of fact, expressed or implied, other than as set forth in the exclusive written limited warranty statement above is made or authorized by 4B. 4B specifically disclaims any liability for product defect claims that are due to product misuse, abuse or misapplications, as authorized by law, 4B specifically disclaims all warranties that the product is fit or merchantable for a particular purpose.

3. NO WARRANTY "BY SAMPLE OR EXAMPLE"

Although 4B has used reasonable efforts to accurately illustrate and describe the products in its catalogs, literature, and websites, such illustrations and descriptions are for the sole purpose of product identification and do not express or imply a warranty affirmation of fact, of any kind or a warranty or affirmation of fact that the products will conform to their respective illustrations or descriptions. 4B expressly disclaims any warranty or affirmation of fact, expressed or implied, other than as set forth in the exclusive written limited warranty statement above, including, without limitation, the implied warranties of merchantability and fitness for a particular purpose.

4. LIMITATION OF DAMAGES

Any liability for consequential, incidental, special, exemplary, or punitive damages, or for loss of profit whether direct or indirect, is expressly disclaimed.

With subsidiaries in North America, Europe, China, Asia, Africa and Australia along with a worldwide network of distributors, 4B can provide practical solutions for all your applications no matter the location.



4B BRAIME COMPONENTS LTD.

Hunslet Road
Leeds
LS10 1JZ
United Kingdom
Tel: +44 (0) 113 246 1800
Fax: +44 (0) 113 243 5021

4B DEUTSCHLAND

9 Route de Corbie
80800 Lamotte Warfusée
France
Tel: +49 (0) 700 2242 4091
Fax: +49 (0) 700 2242 3733

4B AFRICA

14 Newport Business Park
Mica Drive, Kya Sand
2163 Johannesburg
South Africa
Tel: +27 (0) 11 708 6114
Fax: +27 (0) 11 708 1654

4B FRANCE

35 Bis Rue Du 8 Mai 1945
80800 Villers, Bretonneux
France
Tel: +33 (0) 3 22 42 32 26
Email: 4b-france@go4b.com

4B COMPONENTS LTD.

625 Erie Avenue
Morton, IL 61550
USA
Tel: 309-698-5611
Fax: 309-698-5615

4B ASIA PACIFIC

Build No. 899/1 Moo 20
Soi Chongsiri, Bangplee-Tam
Ru Road, Tanbon Bangpleeyai,
Amphur Bangplee,
Samutprakarn 10540
Thailand
Tel: +66 (0) 2 173-4339
Fax: +66 (0) 2 173-4338

4B China

F1, Building 5A,
Jintong Industrial Park,
8 West Lake Road,
Wujin High & New TDZ,
Changzhou, Jiangsu, PRC
Tel: +86-519-88556006
Email: 4b-china@go4b.com

4B AUSTRALIA

Building 1, 41 Bellrick Street
Acacia Ridge
Queensland 4110
Australia
Tel: +61 (0)7 3216 9365
Fax: +61 (0)7 3219 5837



www.go4b.com